



Novus-B27-000

Technical Manual

TEC-EL-04167
Version 1.0.2

2019-12-19



Version History

Version	Department	Initials	Date	Comments
1.0.0	Engineering		2019-07-23	- Original version
1.0.1	Redaction	SC	2019-09-12	- Verified version
1.0.2	Redaction	MM	2019-12-20	- Correction de la mise en page
				-
				-



Contents

VERSION HISTORY	2
PHYSICAL COMPONENTS	5
CABINET DIMENSIONS.....	5
CABINET DIMENSIONS WITH 27" TOPPER.....	6
EXTERIOR VIEW OF THE MACHINE.....	7
TOWER LIGHT.....	8
TOPPER (OPTIONAL).....	8
DOORS.....	9
INSIDE VIEW OF THE MACHINE.....	15
DOOR SWITCHES.....	17
SWITCH LOCKS.....	18
LOGIC BOX.....	19
ELECTRICAL COMPONENTS	20
POWERING DIAGRAM.....	20
LIST OF ELECTRICAL COMPONENTS.....	21
GAMING BOARD (SPIDER)	22
BOARD DIMENSIONS.....	22
BLOCK DIAGRAM.....	24
GENERAL DESCRIPTION.....	25
PROCESSOR AND MEMORY.....	27
BIOS.....	28
SECURITY.....	29
SOUND AND VIDEO.....	30
INPUTS AND OUTPUTS.....	31
Edge connector.....	31
Expansion Drawer Connector.....	33
Front Panel Connections.....	34
CCTALK.....	39
Miscellaneous.....	40
PERIPHERALS	42
BILL ACCEPTOR (OPTIONAL).....	42
PRINTER (OPTIONAL).....	42
DECK LCD PANEL.....	43
UPPER DOOR LCD MONITORS.....	43
CURVED SIDE LED BARS.....	44
MECHANICAL METERS.....	45



NETWORK	45
POWER DISTRIBUTION UNIT.....	45
SWITCHED AC OUTLETS	48
UNSWITCHED AC OUTLETS	48
AC FAULT CONDITION	49
SOUND AMPLIFIER, SUBWOOFER AND SPEAKERS.....	50
CONTACT US.....	52



Physical Components

Cabinet Dimensions

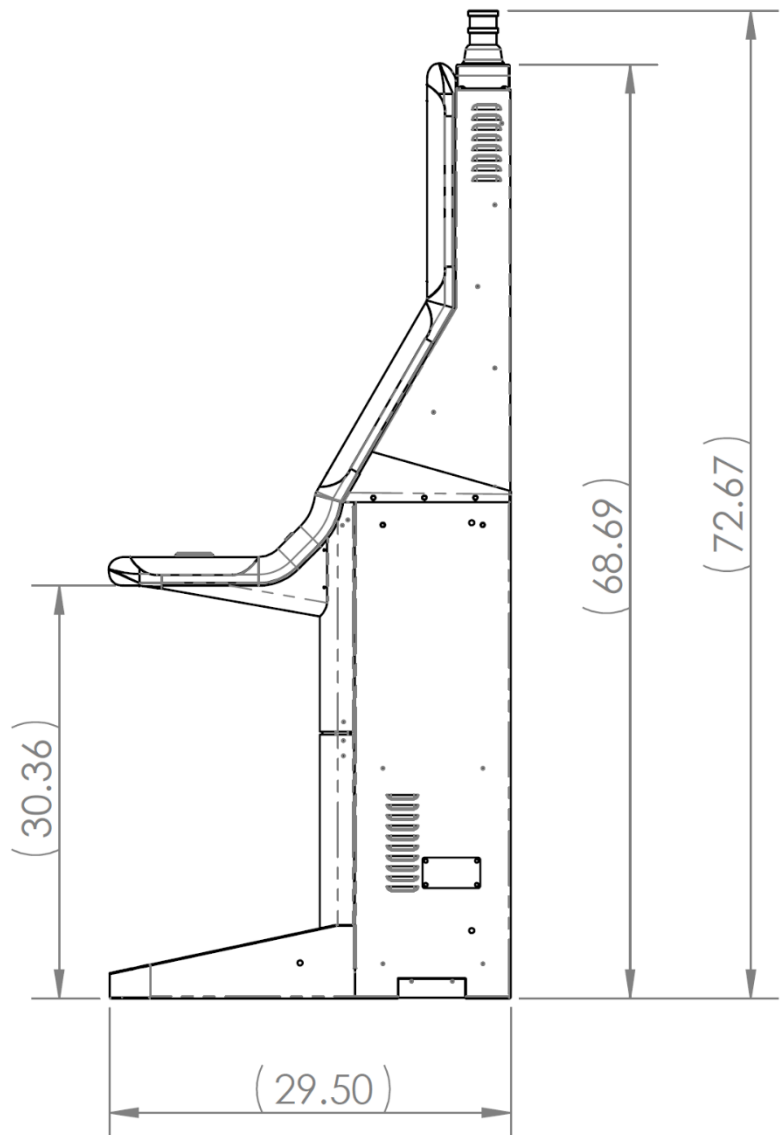
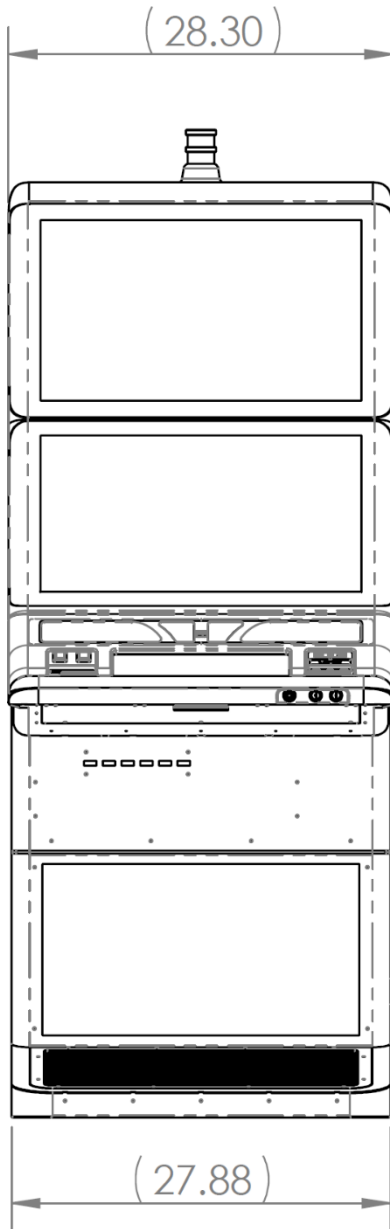

Weight = 204 kg (450 lbs)



Cabinet Dimensions with 27" Topper

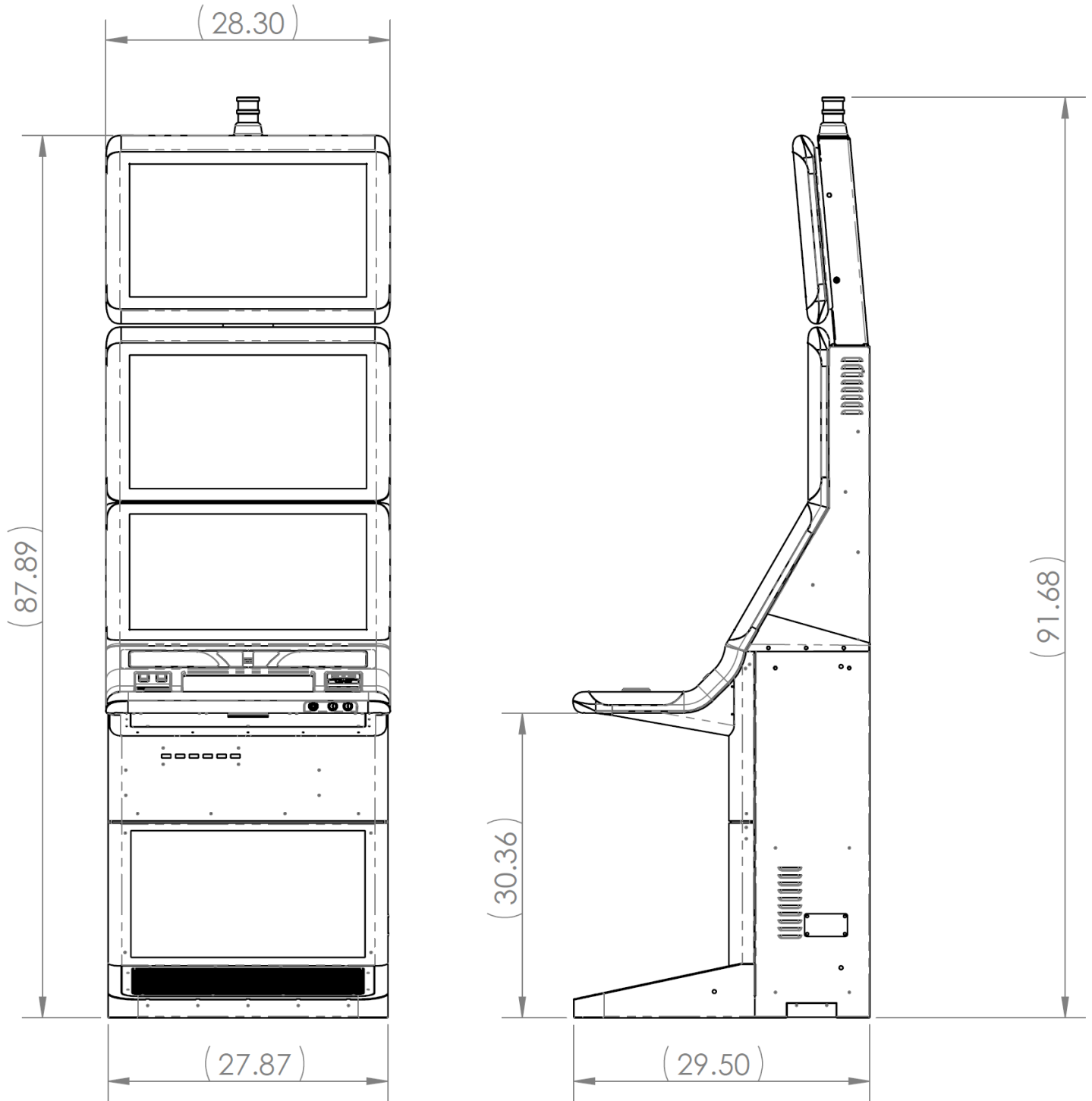

Weight = 228 kg (502 lbs)



Exterior View of the Machine

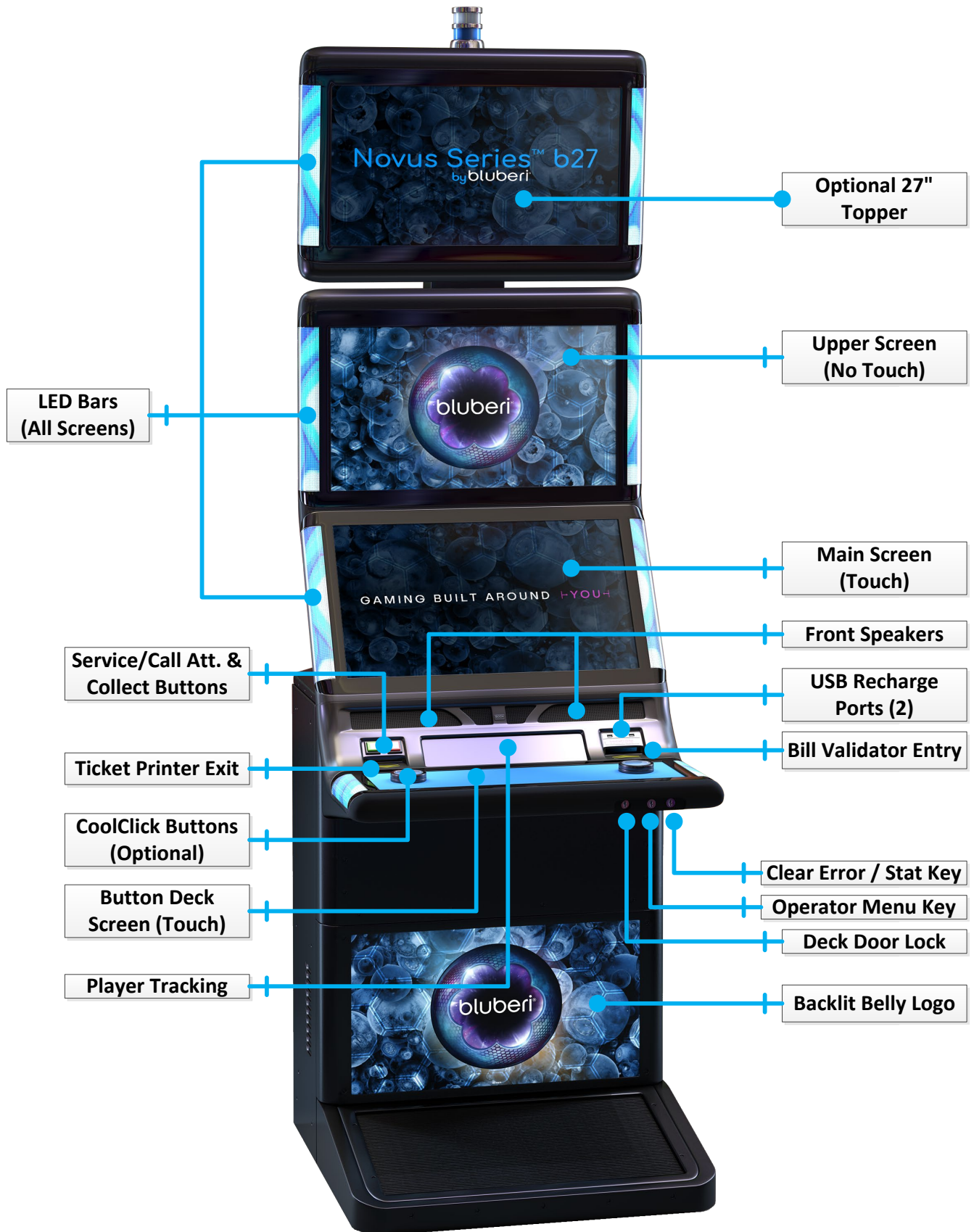

Tower light

Available in 2 or 3 levels, the tower light signals different events, such as a door opening, an attendant call or a jackpot win.



Topper (optional)

The Novus cabinets come with an optional 27" Topper custom built for the Novus series.



Doors

Whenever a door is opened, the tower light flashes. You can open a door safely without losing statistics or interrupting the game in progress.

Keys are provided to unlock various parts of the gaming machine: the deck door, the logic box door and the bill validator door. On the Novus cabinet series, unlocking and opening the deck door gives access to the upper door and footrest area.

NOTE: all keylocks use standard 5/8" locks.



Deck Door Lock

- To open the deck door**
- 1 Unlock the door.
 - 2 Pull the handle towards you.
 - 3 Open the door.

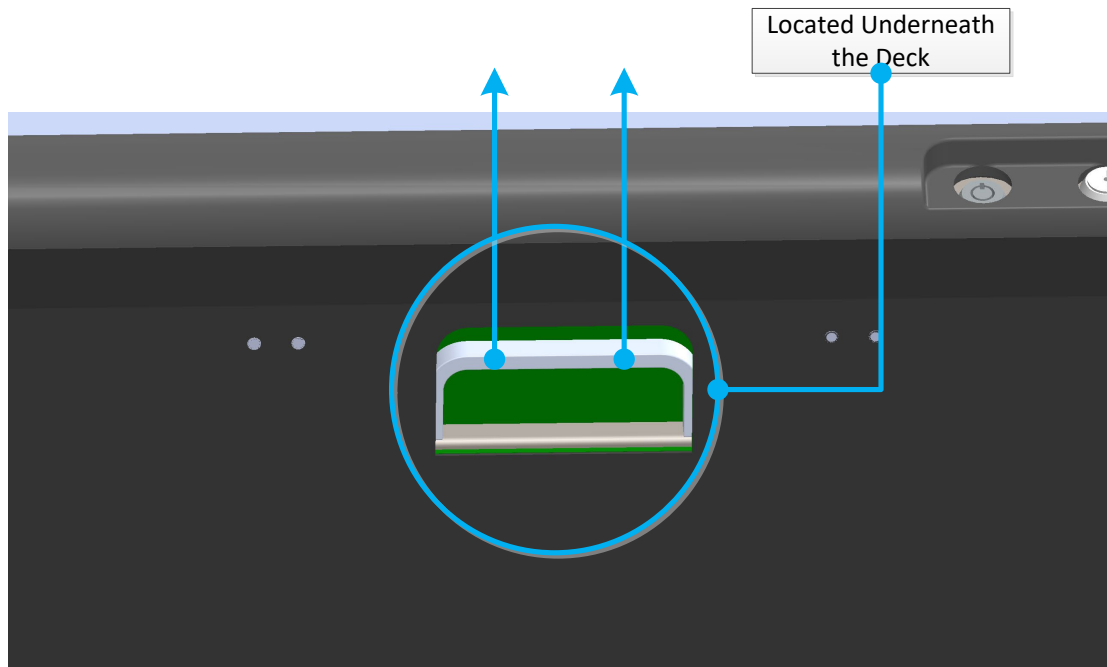

Located Underneath the Deck

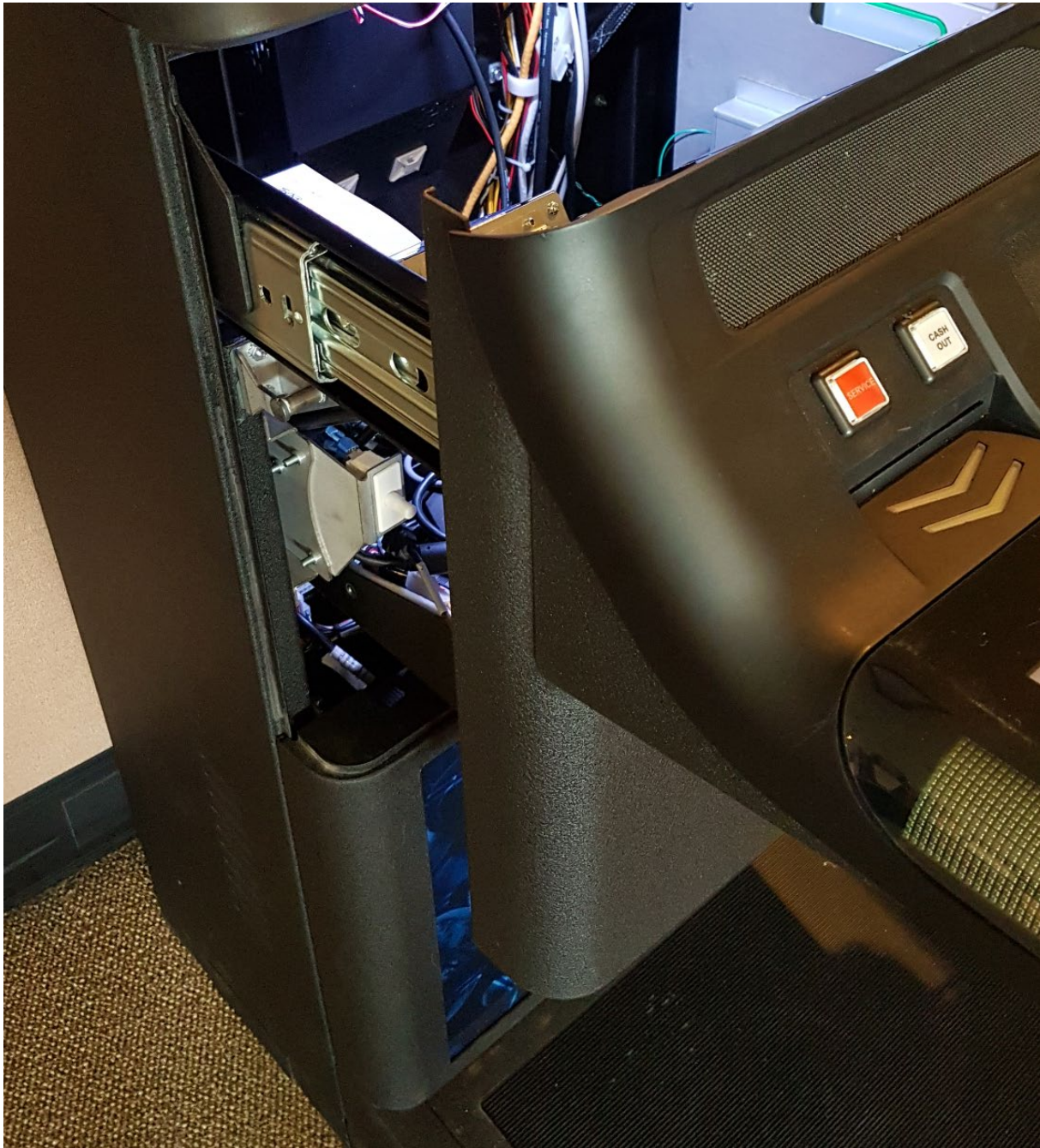

To open the upper door, you need to open the deck door first.

Pull down on both indexing plungers located below the upper door urethane trim using left and right hand at the same time.

While holding both plungers, pull the upper door toward you. The upper door will swing up with unique scissor hinge and give you access to the space behind the upper door.

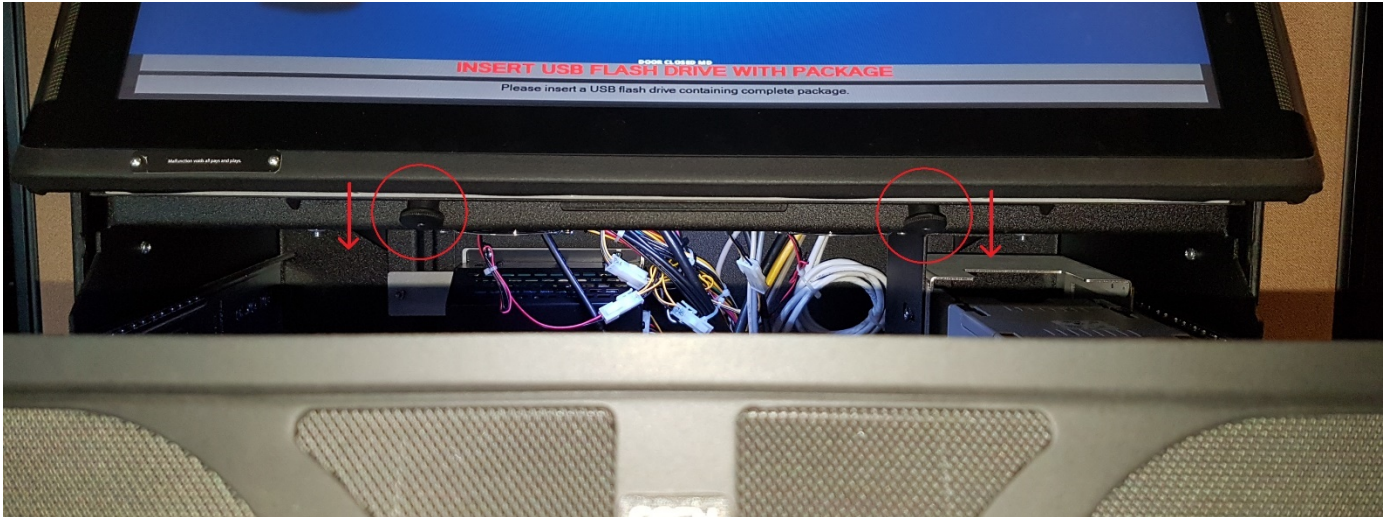

To gain access to the lower section of the cabinet and footrest area, you can easily remove both the belly panel and the footrest plate.

To remove the belly panel, you first need to open the deck door.

Disconnect the power cable going to the backlit belly panel. The connector is located on the left side.



From the top, grab the belly panel assembly using both hands and pull up to release hooks located on both sides.



You can then remove the belly panel assembly from underneath the deck. You now have access to the space behind the belly panel (power distribution unit, subwoofer, etc.).

Removing of the footrest panel will gives you access to all the space inside the footrest area.



Inside View of the Machine

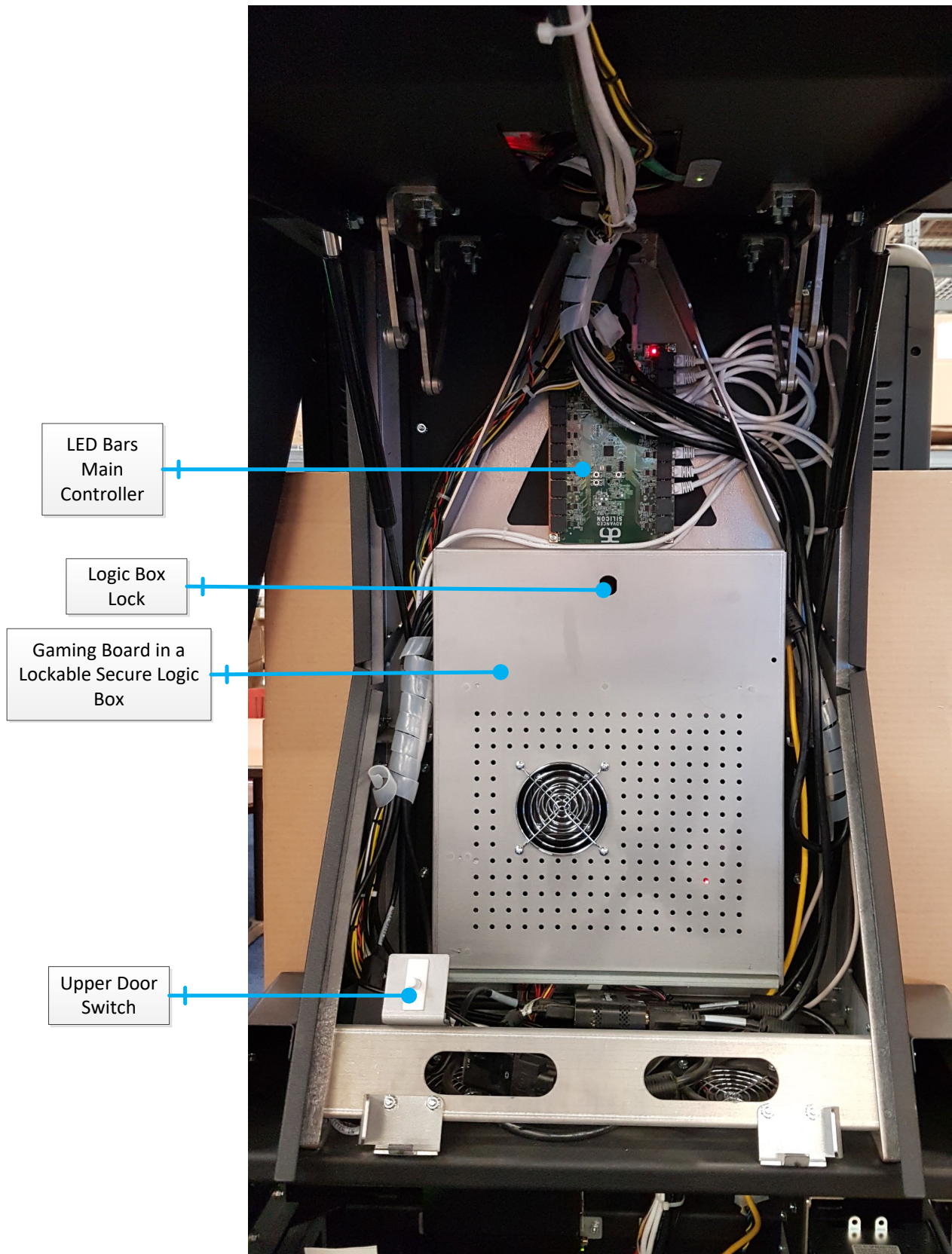

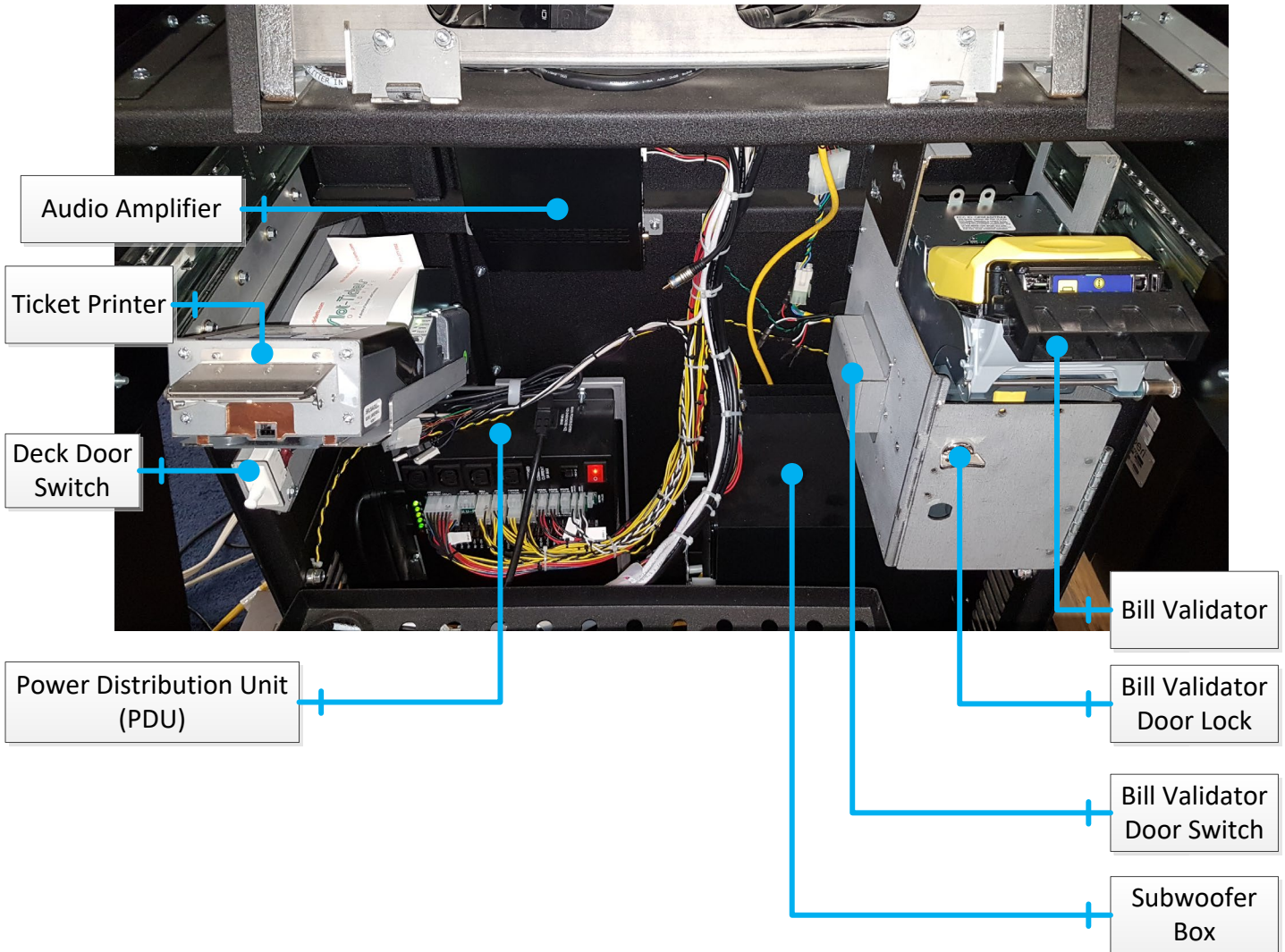

Door Switches

Four switches detect door opening and closing:

- the upper door switch
- the deck door switch
- the bill door switch
- the logic door switch

All switches operate in a “normally closed” mode. Each time a door is opened, its switch closes the electronic circuit, and this event is created and recorded in the event log kept in the gaming board memory.

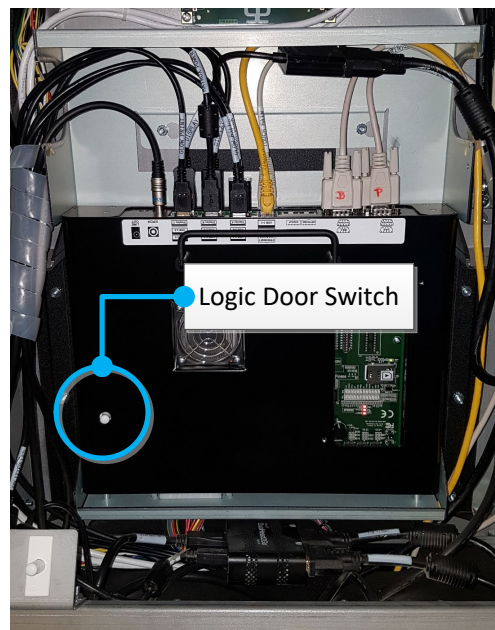
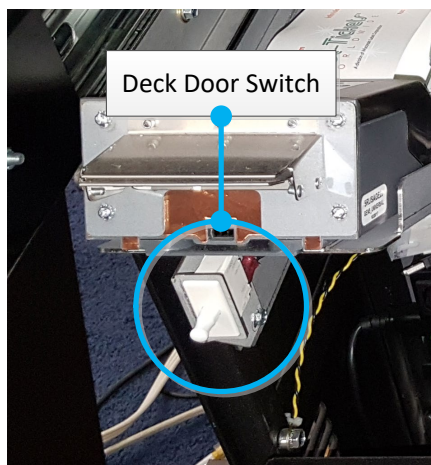
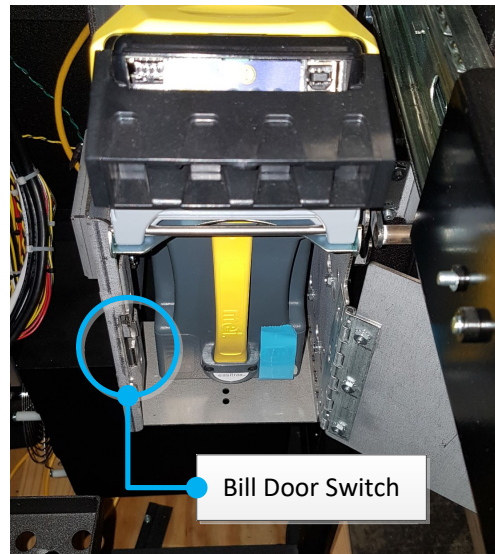
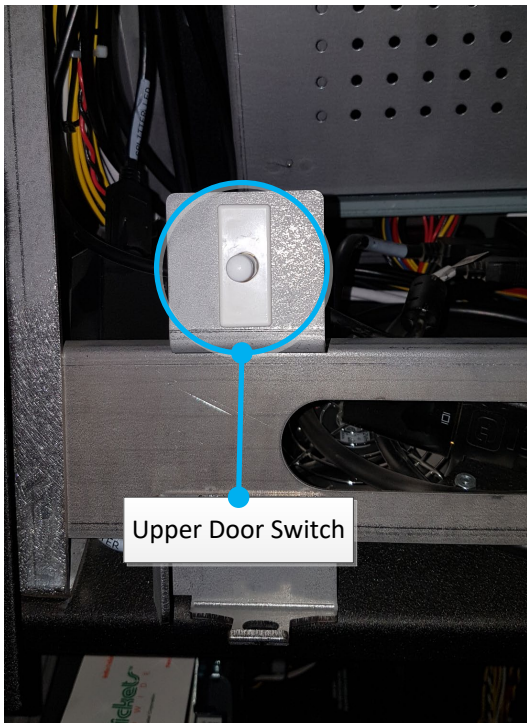

Switch Locks

A single key either provides access to the Operator Menu or is used to clear errors, depending on the switch lock it is inserted into.

The Operator Menu switch lock gives access to the Operator Menu that allows the configuration of the game, self-diagnostic, statistics, and other options. The Clear Error switch lock allows the operator to clear errors once the problem has been solved.

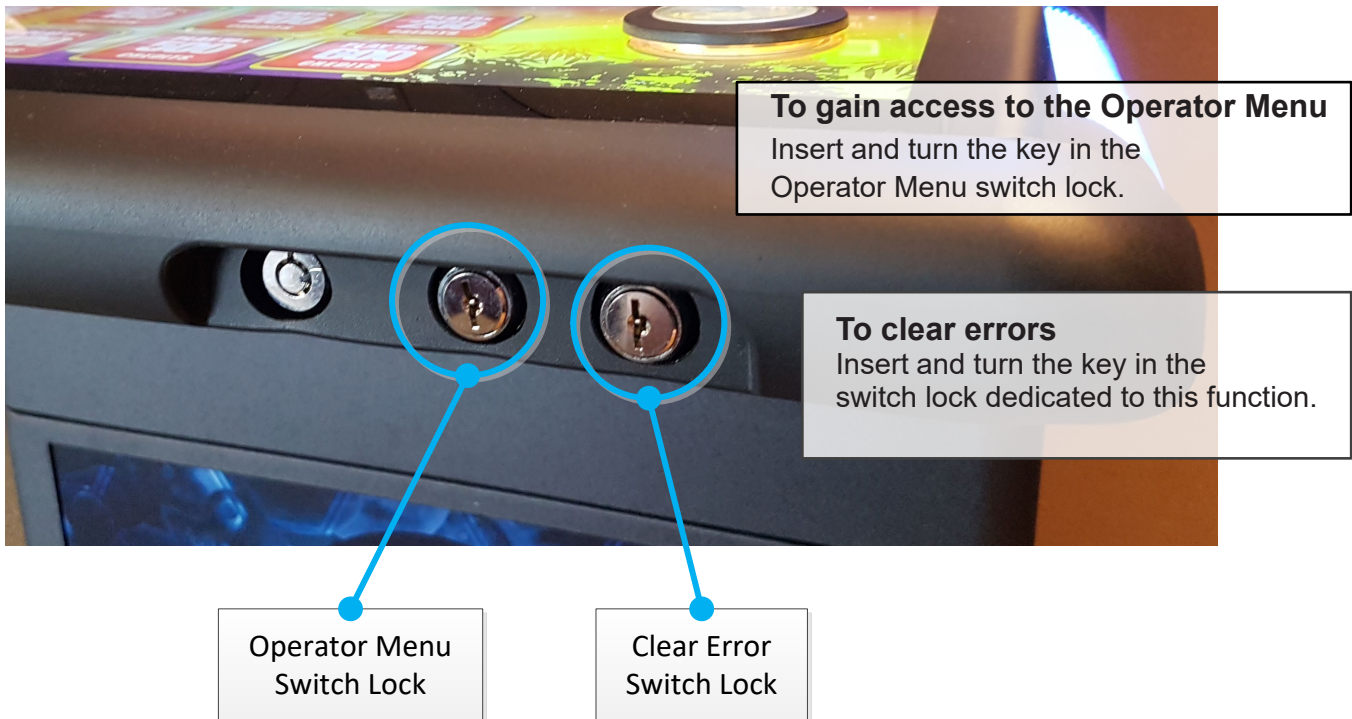

Logic Box

The logic box is a covered metal box housing the gaming board. A door switch detects the opening of the logic box cover. The gaming board reads the state of the logic door switch even when the power is off. The logic box is located at the back of the gaming machine, locked with a key and linked to the machine I/Os through the backplane or through the device connectors.

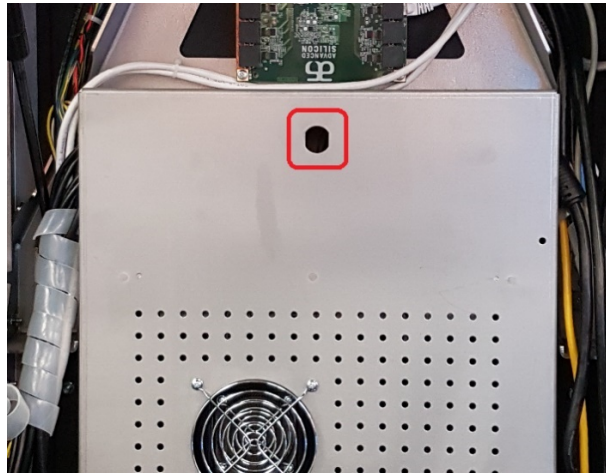

Logic Box Cover Lock Location

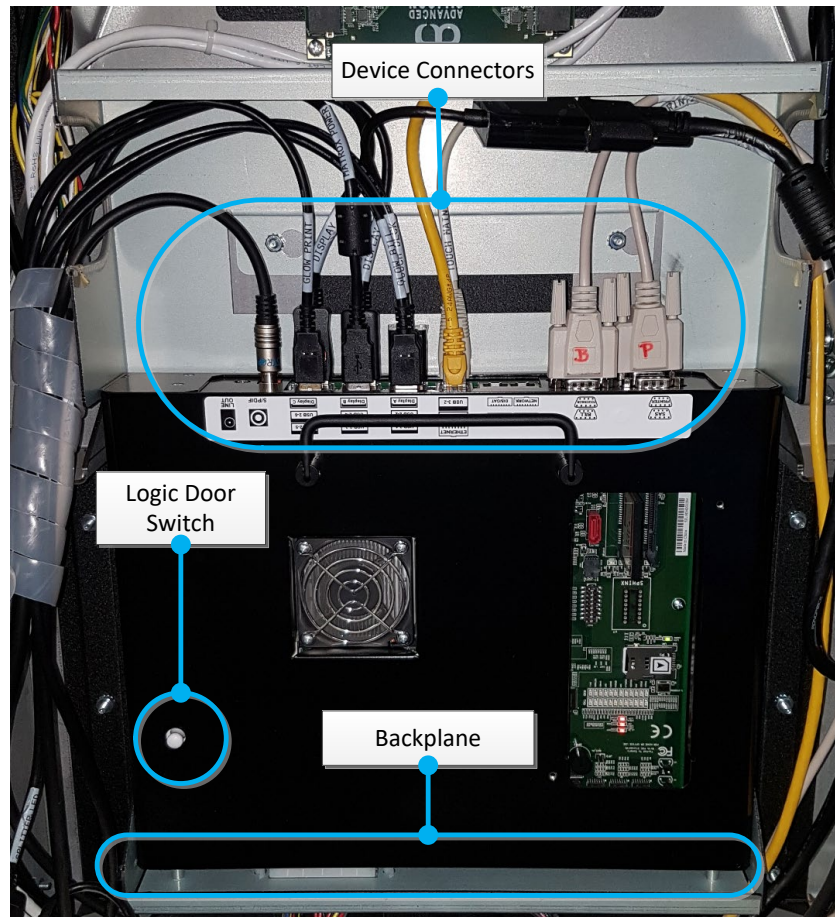

Logic Box Inside View



Electrical Components

Powering Diagram

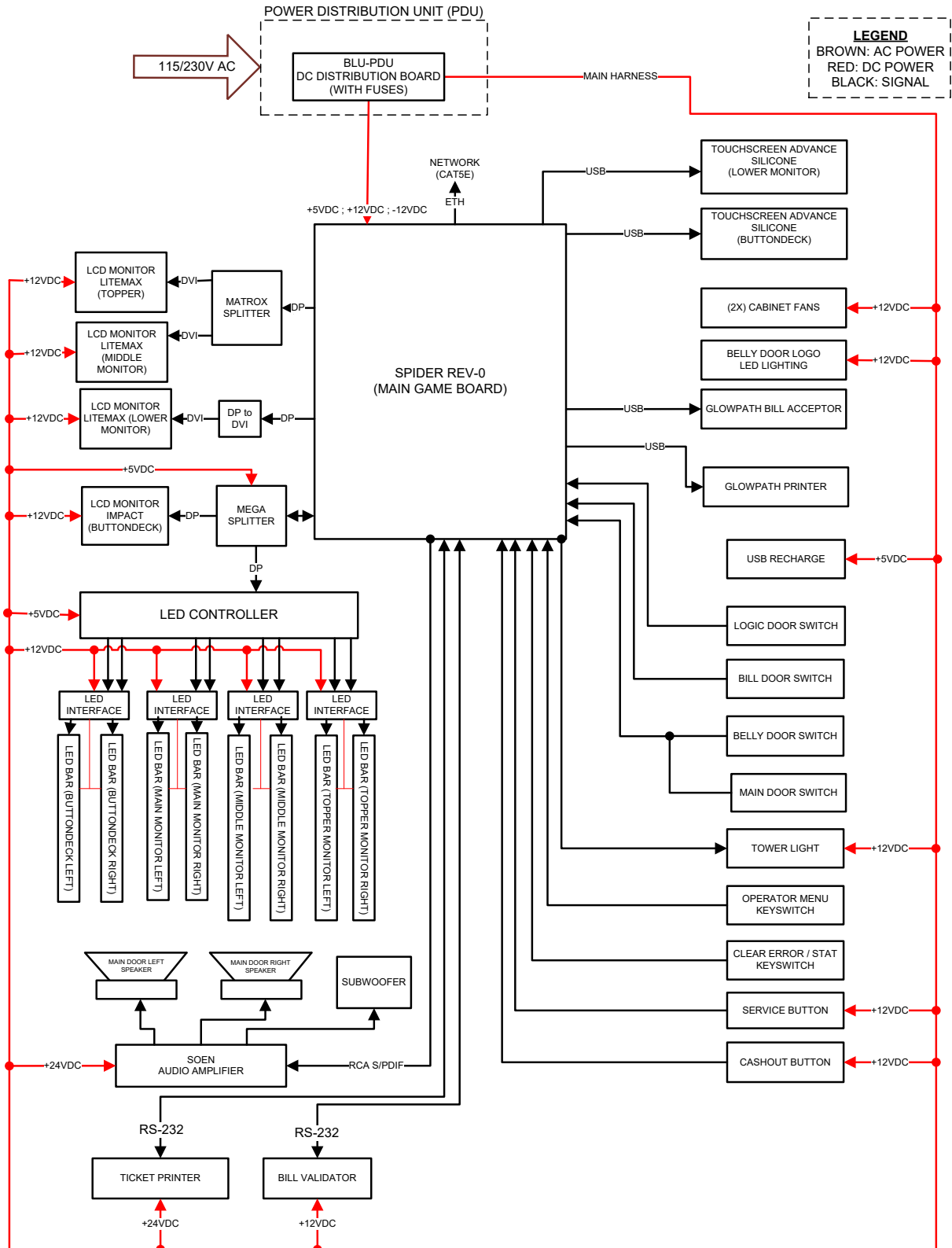



List of Electrical Components

Component		Quantity	Manufacturer	Model
Power Distribution Unit		1	Agape Technology ACPC Group	ATEC-24V750-PDB
Fan		2	Delta Products Corp.	AUB0912VH-CIT
Gaming board		1	Bluberi Gaming Canada Inc.	SPIDER Rev-0
LCD Monitor (upper door)		2	Litemax	DLH2705-BNW-I01
LCD Monitor (topper - optional)		1	Litemax	DLH2705-BNW-I01
LCD Monitor (Deck)		1	Litemax	SSP2443-INW-I02
Service & Cash out Buttons		2	Gamesman	GPB1105-AHQCBZPLA
Door switch	Deck Door	1	ZF Electronics	E79-30A0
	Upper Door	1	ZF Electronics	E79-30A0
	Bill Door	1	ZF Electronics	E79-30A0
	Logic Door (cover)	1	ZF Electronics	E69-30A0
Key Switch	Operator Menu	1	Suzo	30-1086-01 (Constant)
	Clear Error (Stat)	1	Suzo	30-1086-00 (Momentary)
Mechanical meter (optional)		5	Suzo	42-08012-07
Tower light		1	Suzo	11-1882
Side LED Main Controller		1	Advanced Silicon	RDK551001V1100141071
Sound System		1	Soen Audio	NOVUS Series System

Gaming Board (Spider)

Board Dimensions

With Enclosure

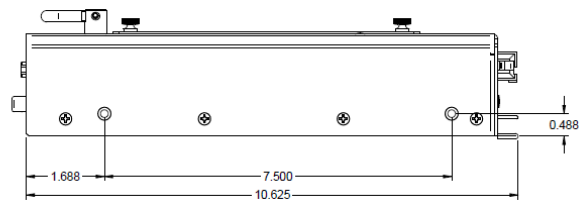
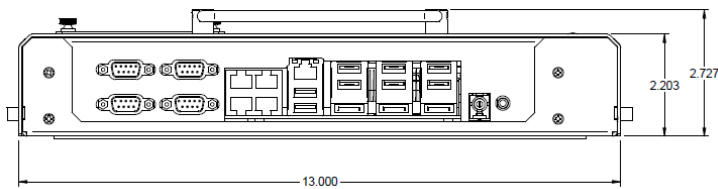
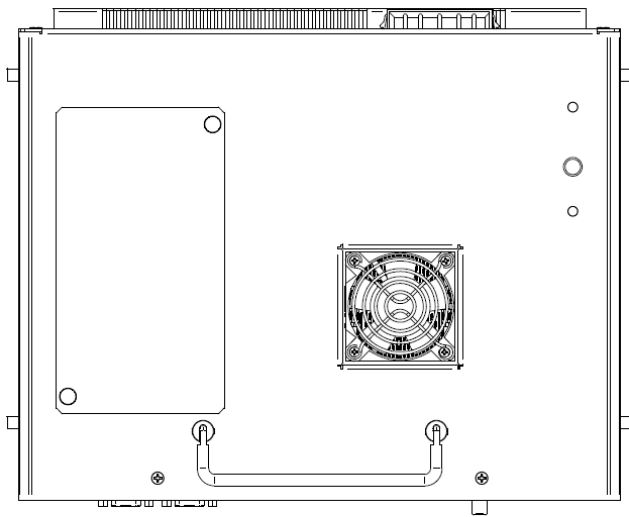



Without Enclosure

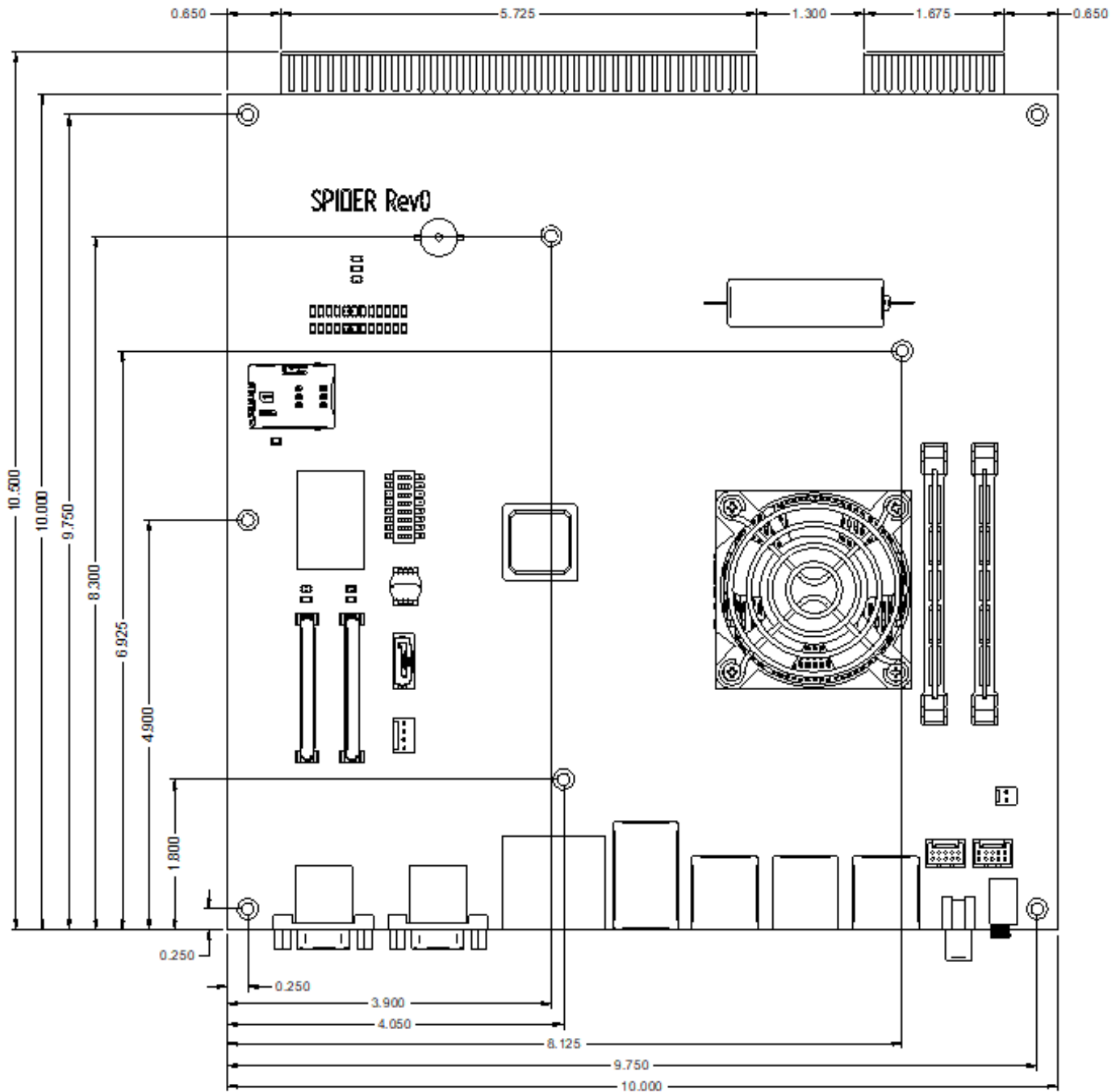



Block Diagram

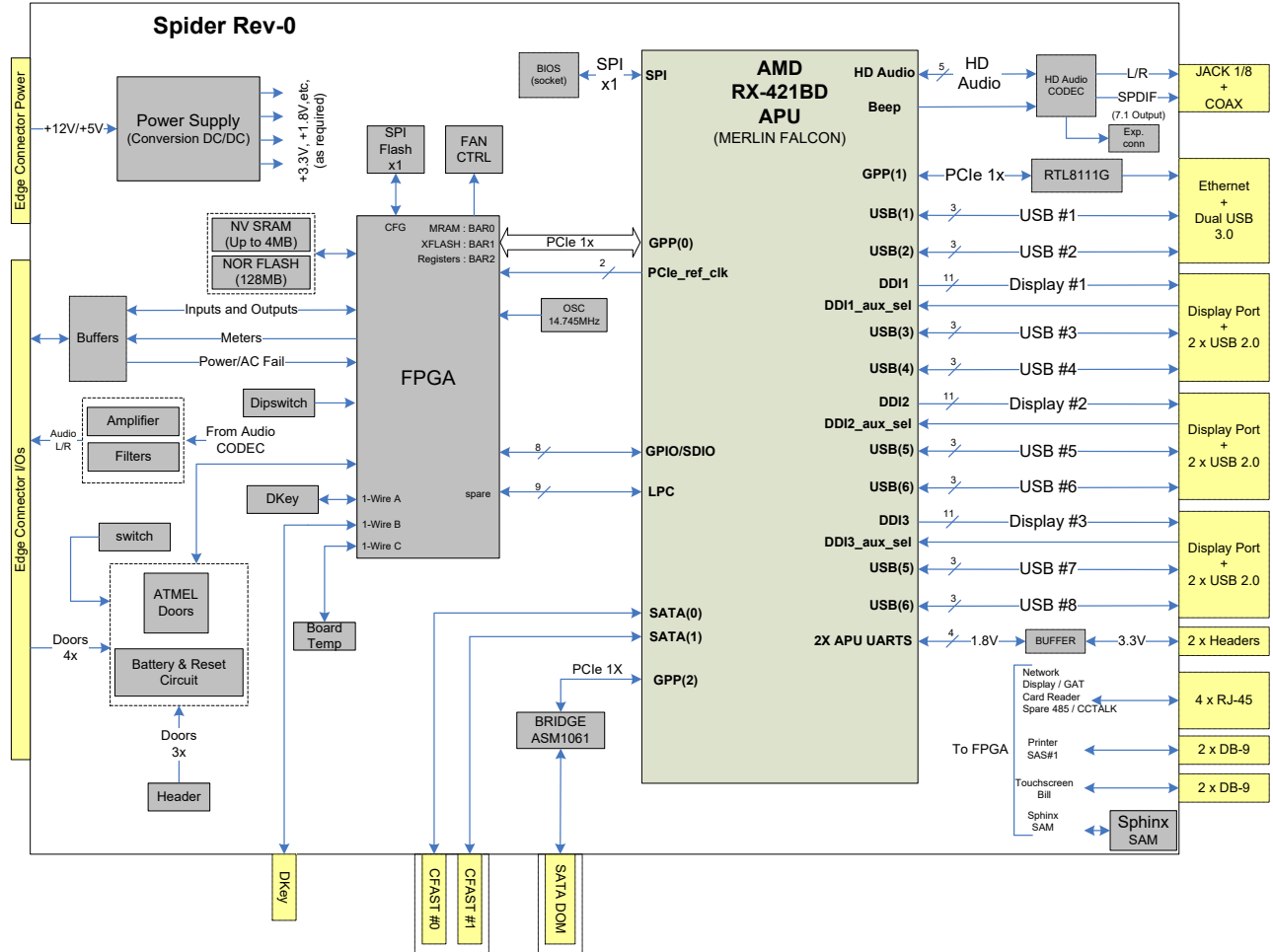



General Description

Chipset

- AMD embedded APU Merlin Falcon R-Series RX-421BD (excavator Quad cores, 2.1-3.4GHz, R7 GPU with 8x GCN cores @ 800MHz, 12-35W TDP).

Display

- 3x Digital Display Interface (DDI) on Display Port connector. Each DDI supports the Dual-Mode Implementation (also called DP++). This feature gives the option to link the monitor with a Display Port cable or a passive Display Port to DVI cable/adapter.

Sound

- ALC888 HD Audio CODEC linked to the APU.
- PC speaker (buzzer).
- Digital interface (S/PDIF).
- Jack 1/8 plug for the analog interface.
- Onboard expansion connector for the HD Audio interface (7.1) and microphone input.
- Onboard audio amplifier providing at least 20W/channel for 2 channels (left/right). The amplified output is going goes to the edge connector.

USB

- 2x USB 3.0 ports available on the front panel. The maximum allowable current to be drained from the USB 3.0 ports is limited to 1.1A.
- 6x USB 2.0 ports available on the front panel. The maximum allowable current to be drained from the USB 2.0 ports is limited to 500mA.

Ethernet

- 1x 10/100/1000 MBPS Integrated Ethernet Controller (front panel connector RJ45).
- Fully compliant with IEEE 802.3, 802.3u and 802.3ab.

Serial ATA

- 2x CFAST sockets supporting SATA 3.0 (data transfer up to 6GB/s).
- 1x On-board SATA connector using SATA 3.0 with optional +5V power on pin #7 for SATA DOM.

APU Memory (DDR4)

- Dual channel DDR4-2133MHz SODIMM sockets (up to 2x32GB memory theoretical with 2GB of GPU shared memory).



BIOS

- AMI BIOS.
- A Coreboot BIOS will be developed later to enable compliance with security features required in jurisdictions such as Nevada state.
- The BIOS is programmed into an SPI flash installed on a Zero Insertion Force (ZIF) SOIC-8 socket. This is a requirement for some jurisdictions.

Serial Ports

- 4x RS232 on male DB9 connector (Printer, SAS, Touchscreen and Bill*).
- 3x RS232 on modular jack connector (Display**, GAT** and Spare232).
- 2x RS485 on modular jack connector (Network and Spare485***).
- 1x CCTALK*** on modular jack connector.
- 1x CCTALK on 4 pins connector.

* Can be configured as TTL or RS232 simulated.

** Share the same modular jack.

*** Share the same modular jack.

DOOR Controller

- The system is responsible for monitoring up to 8 different door events.
- Real Time Clock chip.
- Lithium AA Battery, 3.6V, 1900mA.

Memories

- 4MBytes of non-volatile SRAM with hardware lock. The approved technologies are Everspin MRAM and Cypress nvSRAM.
- 128MBytes of NOR flash (can be used to store logs or any game operation information).

Security

- 16-pins machined socket to host a proprietary security device (SPHINX).
- 8-pins SIM card connector (push in/push out) to host a proprietary security card (SAM).

Miscellaneous

- 1-wire DS2502 Dallas key (holds Spider board unique serial number and IEEE OUI MAC address).
- External 1-wire interface on a 2-pin header.
- 1-wire sensor for ambient temperature.
- Fan control with PWM and sensing of the fan speed. Fan power is selectable between +5V and +12V.
- Pack of 8 dip switches.
- Power loss detection (AC-FAIL et POK).

Processor and Memory

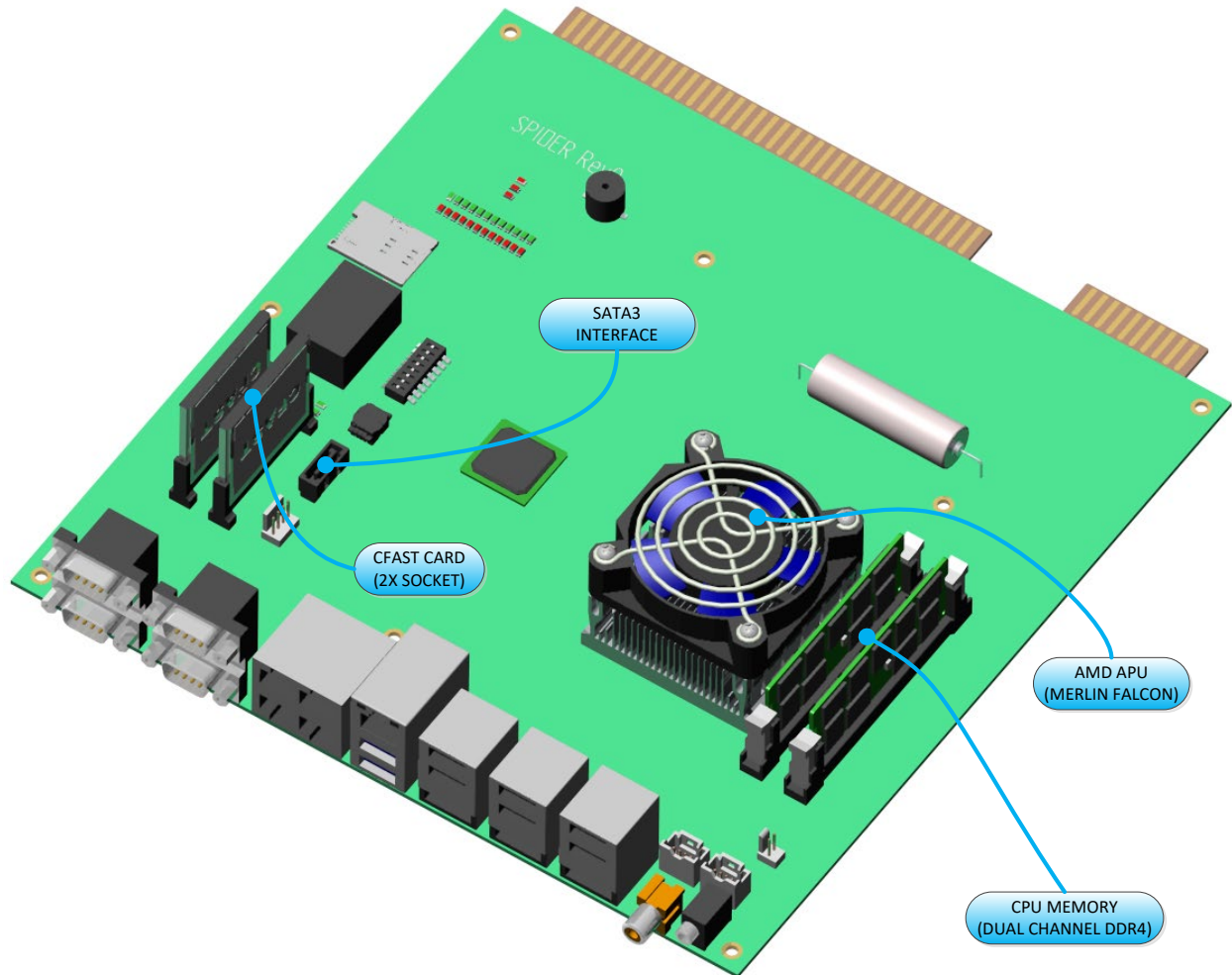

Serial ATA Connector

PIN	FUNCTION
1	GND
2	TX+
3	TX-
4	GND
5	RX-
6	RX+
7	GND*

*Optional +5VDC power according to assembly option (contact vendor)

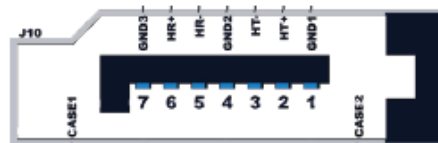

BIOS

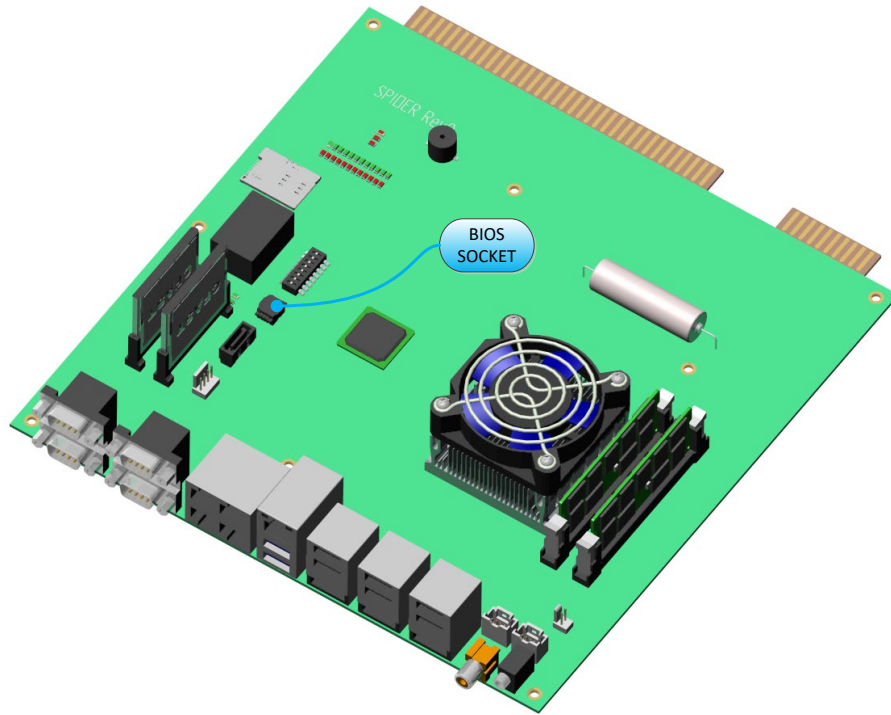

Features an AMI BIOS or Coreboot BIOS. SPI flash (SOIC 8-pins) installed on a clamshell socket to allow easy removal and verification (signature) from required jurisdiction.

Security

Door Tracking Controller:

Up to eight (8) door access monitoring inputs even when power is off, keeping track of the date and time (four available from edge connector and four from 24-pin drawer connector).

SAM Card:

Software protection against piracy and software modification.

SPHINX:

Software protection against piracy and software modification.

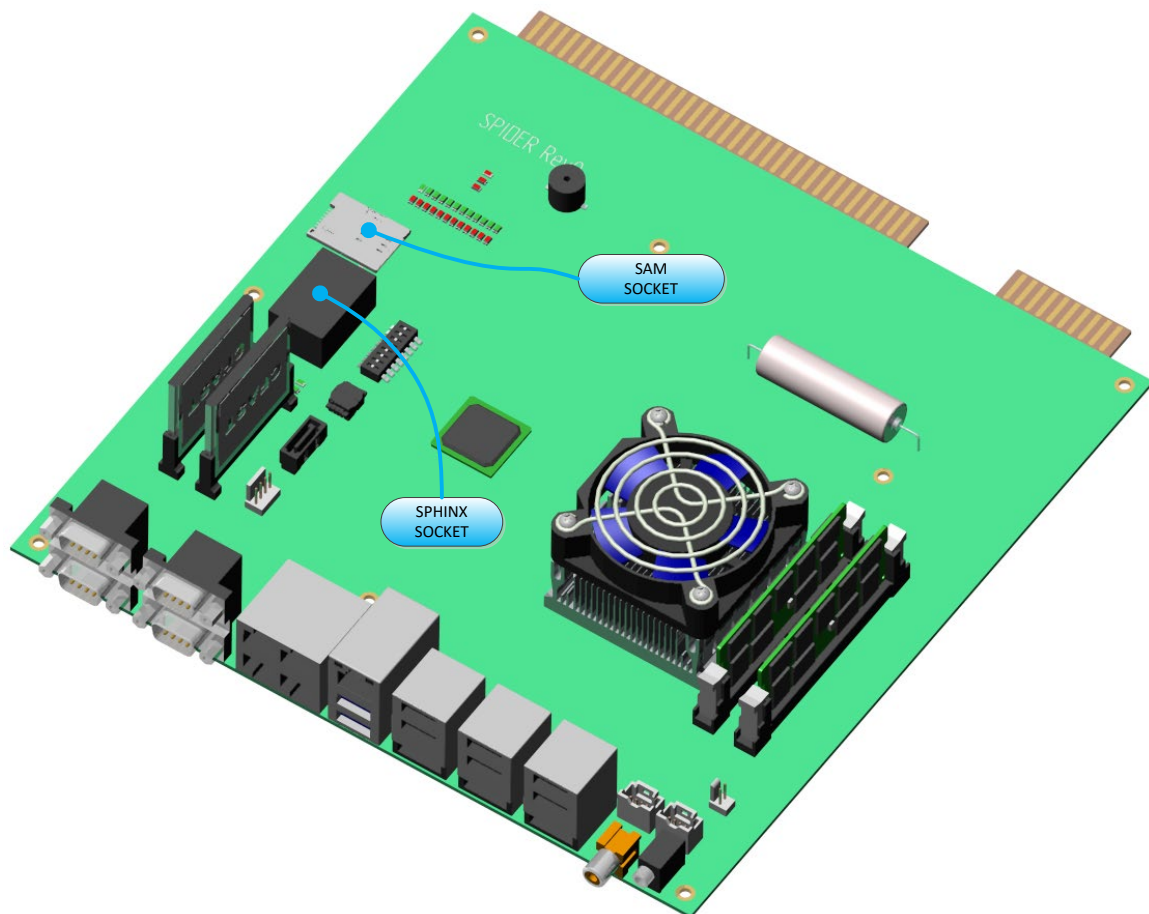

Sound and Video

Spider CPU comes with three native DP++ (Display Port) digital interfaces. DP++ interface can be used with an appropriate passive adaptor cable to get DVI or HDMI. An active adaptor is also available on the market to convert display port signal to VGA (HD15).

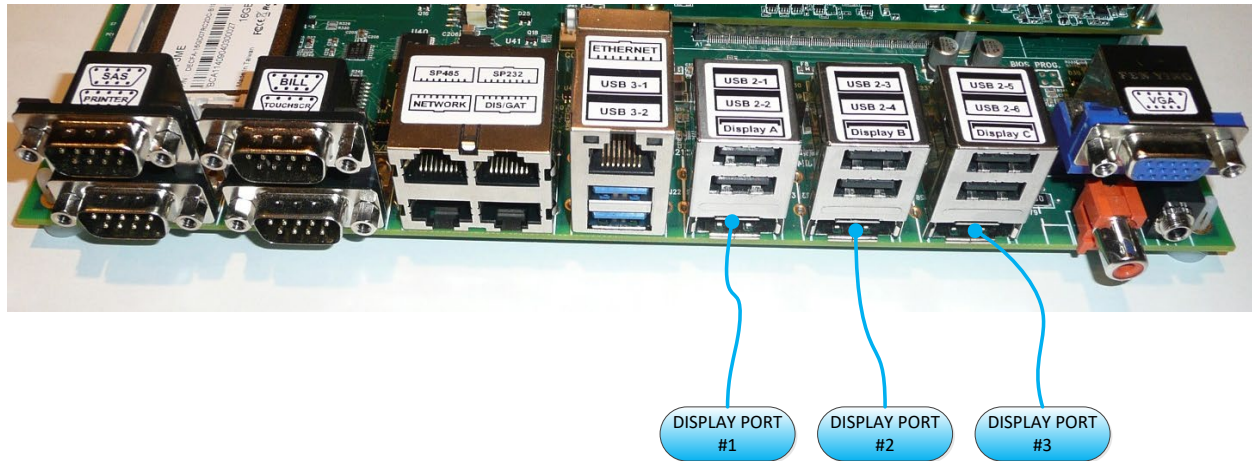

Sounds on the Spider CPU are generated from a Realtek ALC888S HD audio codec. A 1/8" jack and S/PDIF RCA are available in the front panel. It is also possible to have access to additional audio channel and microphone inputs from an expansion front panel connector. The Spider supports up to 7.1 audio channels using S/PDIF digital interface.



An amplified stereo output (2x20W) is also available from the edge connector. See edge connector section for pinout.

Inputs and Outputs

Edge connector

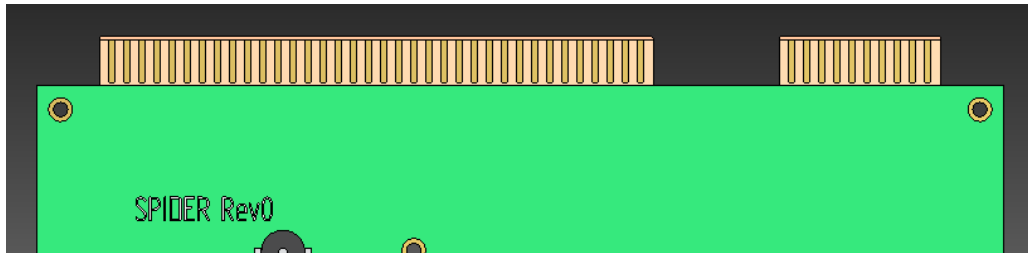

Available from edge connector:

- 31x digital inputs and 31x digital outputs (500mA, 50V max.);
- 4x door monitoring inputs (4 additional available on drawer connector);
- Amplified stereo output for speakers;
- 6x dedicated mechanical meters outputs;
- Power output for mechanical meters;
- AC monitoring circuit (early power failure detection).

20-PIN EDGE (POWER)

Part Side	Pin	Solder Side
GND*	1	GND*
AC+	2	AC-
+5VDC*	3	+5VDC*
+5VDC*	4	+5VDC*
+12VDC*	5	+12VDC*
PWR_METERS**	6	PWR_METERS**
POK	7	HOPPER ENABLE
-	8	TICKET
GND*	9	GND*
GND*	10	GND*

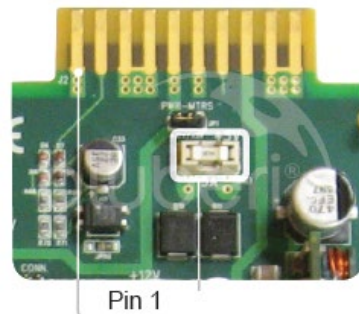

* These pins require an independent wire coming directly from the cabinet power supply or PDU. We recommend using 18Ga wire.

** Do not use to power peripherals other than meters.



72-PIN EDGE (FULL PINOUT)

Part Side	Pin	Solder Side
SPARE METER #2	1	OUT1S
OUT2P	2	OUT2S
LEFT SPEAKER+	3	OUT3S
IN4P	4	LEFT SPEAKER-
SW HOPPER SENSE	5	RIGHT SPEAKER-
IN6P	6	IN6S
IN7P	7	IN7S
IN8P	8	IN8S
IN9P	9	IN9S
IN10P	10	IN10S
IN11P	11	IN11S
IN12P	12	RIGHT SPEAKER+
IN13P	13	SW CASH DOOR
IN14P	14	SW LOGIC DOOR
SW BILL DOOR	15	SW MAIN DOOR
IN16P	16	OUT16S
+5VDC (OUT)*	17	HOPPER DIVERTER
SW SLOT #1	18	SW SLOT #3
SW SLOT #2	19	COIN ENABLE
KEYSW CLEAR ERROR	20	KEYSW OPERATOR MENU
IN21P	21	IN21S
SW HOPPER FULL	22	SW HOPPER COIN
CASH IN METER	23	GND
CASH PLAYED METER	24	OUT24S
SPARE METER #1	25	IN25S
CASH WON METER	26	IN26S
IN27P	27	OUT27S
CASH PAID METER	28	OUT28S
OUT29P	29	OUT29S
OUT30P	30	OUT30S
OUT31P	31	OUT31S
OUT32P	32	OUT32S
OUT33P	33	CANDLE 3H/2L
CANDLE 3M/2H	34	CANDLE 3L
OUT35P	35	IN35S
GND	36	GND

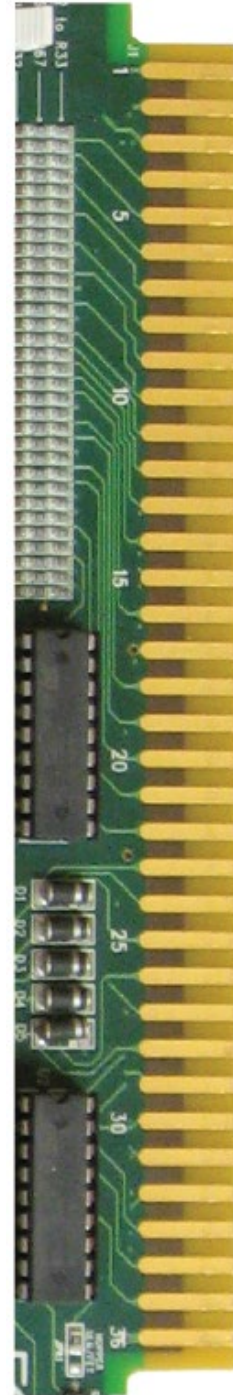

* Do not use to power peripherals.

Expansion Drawer Connector



24-PIN DRAWER CONNECTOR

PIN	FUNCTION
1	+3.3VDC
2	+3.3VDC
3	GND
4	+5VDC
5	GND
6	+5VDC
7	GND
8	POK PSU
9	+5VSB PSU
10	+12V
11	SW DOOR5
12	DKEY+
13	+3.3VDC
14	-12VDC
15	GND
16	SW DOOR6
17	SW DOOR7
18	GND (LOGIC)
19	GND
20	SW DOOR8
21	+5VDC
22	+5VDC
23	SW LOGIC DOOR (LOOP)
24	DKEY-

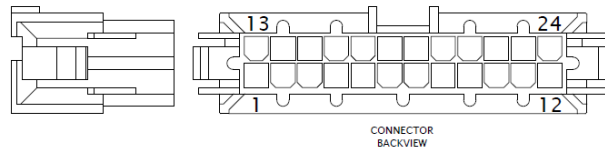

Front Panel Connections

Serial Ports (RS232 & RS485)

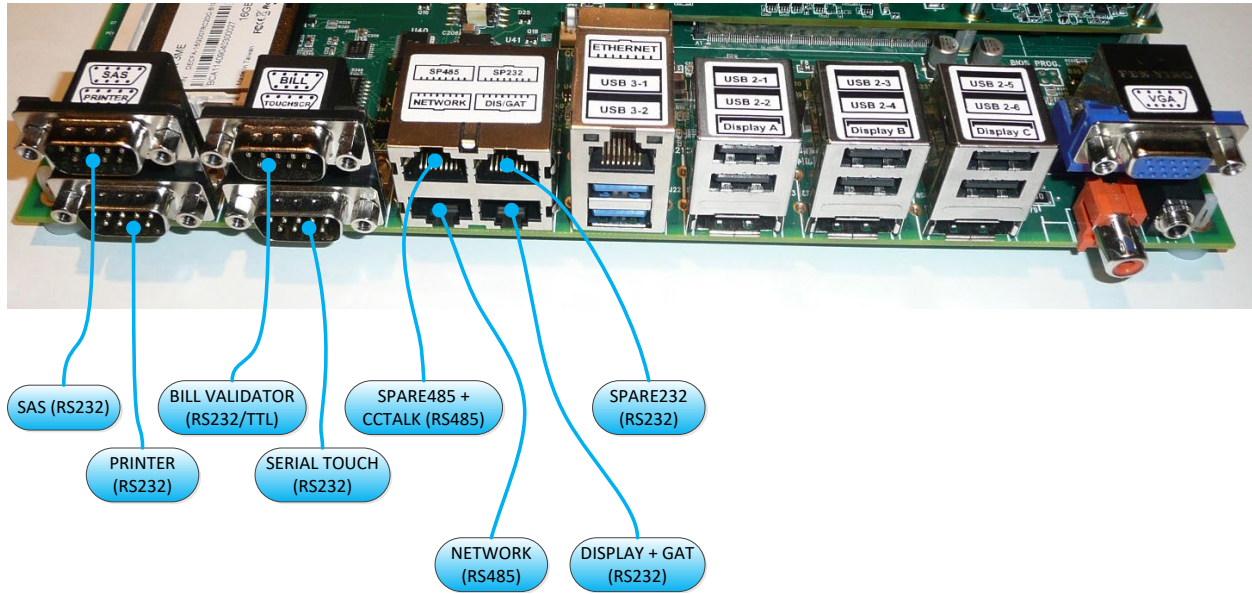

SAS DB-9 Connector

PIN	FUNCTION
1	NC
2	RXD
3	TXD
4	DTR
5	GND
6	DSR*
7	RTS
8	CTS*
9	NC

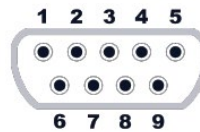

* According to JP1 (handshake signal jumper)

Printer DB-9 Connector

PIN	FUNCTION
1	NC
2	RXD
3	TXD
4	DTR
5	GND
6	DSR*
7	RTS
8	CTS*
9	NC

* According to JP2 (handshake signal jumper)

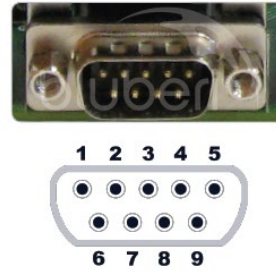

Bill Validator DB-9 Connector

PIN	FUNCTION
1	NC
2	RXD
3	TXD
4	BILL ENABLE
5	GND
6	NC
7	RTS
8	CTS
9	NC

Can be configured as TTL or RS232 simulated

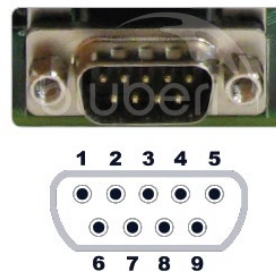

Serial Touch DB-9 Connector

PIN	FUNCTION
1	NC
2	RXD
3	TXD
4	DTR
5	GND
6	DSR*
7	RTS
8	CTS*
9	NC

* According to JP4 (handshake signal jumper)

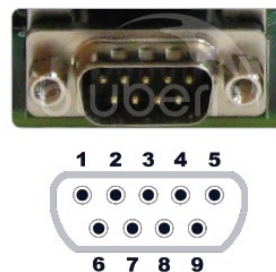

Spare485 + CCTALK RJ-45 Connector (RS485 + CCTALK)

PIN	FUNCTION
1	CCTALK RJ45
2	DOUT-
3	DOUT+
4	GND
5	GND
6	DIN+
7	DIN-
8	NC



Network RJ-45 Connector (RS485)

PIN	FUNCTION
1	DOUT+
2	DOUT-
3	DIN+
4	GND
5	GND
6	DIN-
7	NC
8	NC



Spare232 RJ-45 Connector (RS232)

PIN	FUNCTION
1	NC
2	RTS
3	TXD
4	GND
5	GND
6	RXD
7	CTS
8	NC



Display + GAT RJ-45 Connector (RS232)

PIN	FUNCTION
1	RXD GAT
2	TXD GAT
3	TXD DISP.
4	NC
5	RXD DISP.
6	NC
7	GND
8	GND



Ethernet and USB

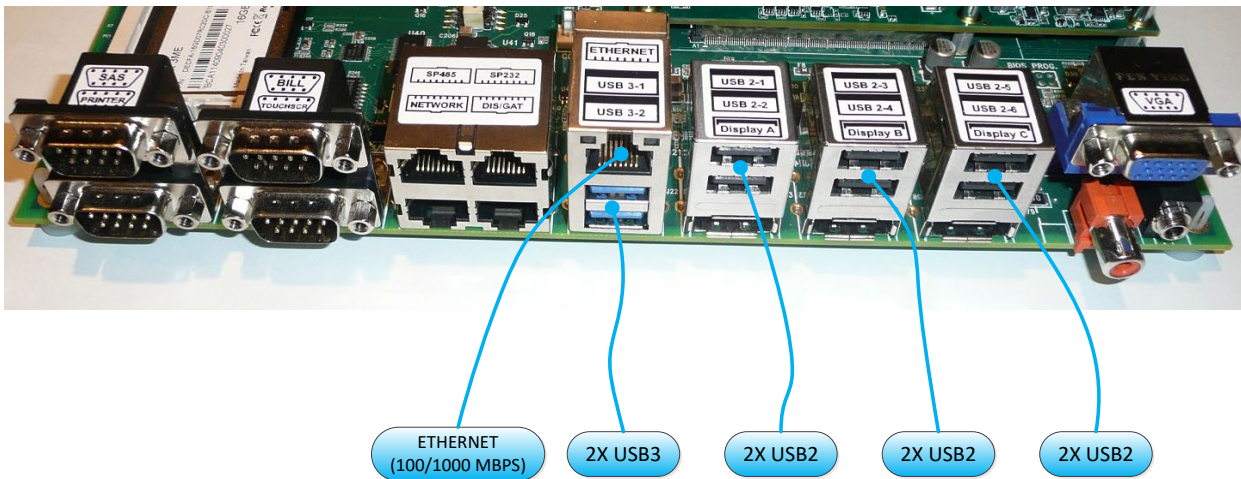

Ethernet RJ-45 Connector (10/100/1000 MBPS)

PIN	FUNCTION
1	TXRX A+
2	TXRX A-
3	TXRX B+
4	TXRX C+
5	TXRX C-
6	TXRX B-
7	TXRX D+
8	TXRX D-



USB2 Connector

PIN	FUNCTION
1	+5VDC*
2	DAT-
3	DAT+
4	GND

*+5VDC current limited to 500mA for USB2



USB3 Connector

PIN	FUNCTION
1	+5VDC*
2	DAT-
3	DAT+
4	GND
5	STDA_SSRX-
6	STDA_SSRX+
7	GND DRAIN
8	STDA_SSTX-
9	STDA_SSTX+

*+5VDC power limited to 1.1A for USB3

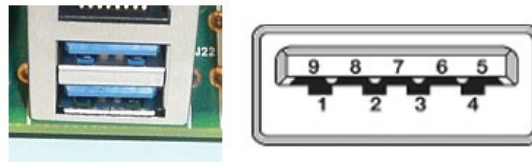

CCTALK

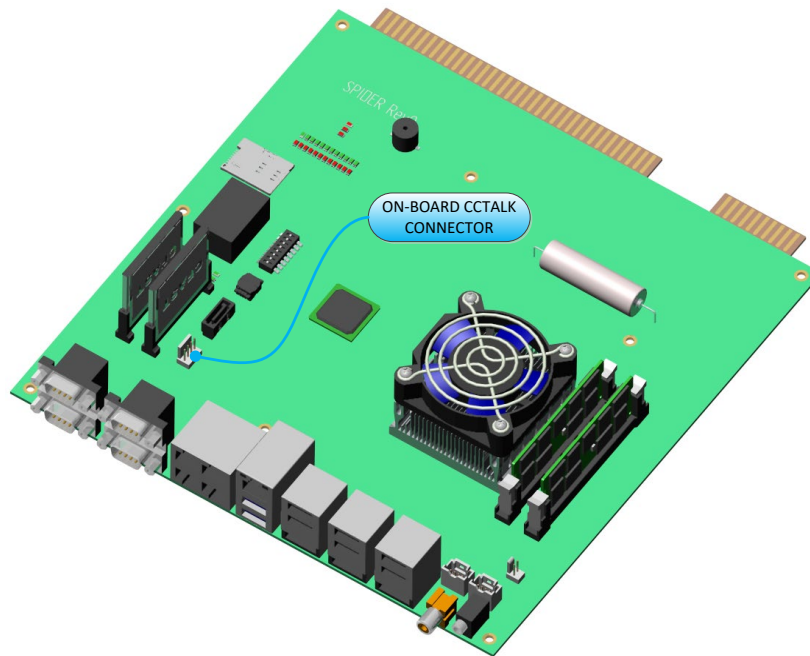

CCTALK Connector

PIN	FUNCTION
1	CCTALK DATA
2	GND
3	NC
4	+12VDC



Miscellaneous

DIP Switch

An 8-position DIP switch is available on the Spider CPU for software configuration.

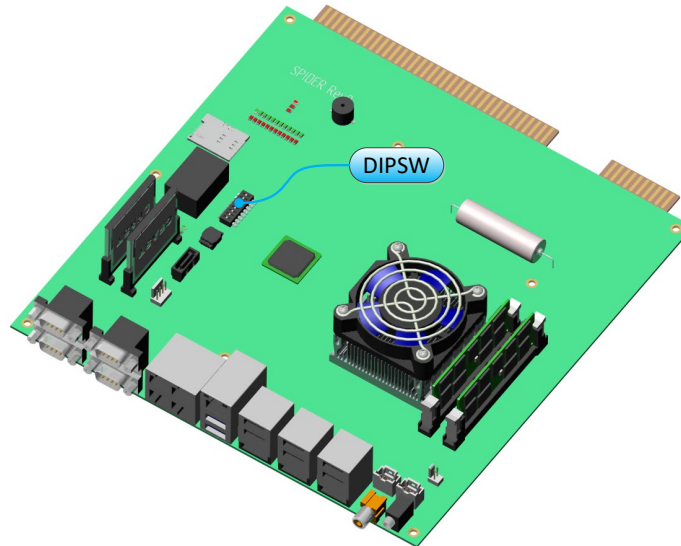

DIPSW#	POS	FUNCTION
DIP SWITCH #1	OFF	NORMAL START-UP (LOAD CFAST GAME)
	ON	REMAINS IN APPLICATION LOADER APP.
DIP SWITCH #2	OFF	IP ADDRESS REQUESTED FROM DHCP
	ON	DISABLE ETHERNET
DIP SWITCH #3	OFF	RESERVED
	ON	RESERVED
DIP SWITCH #4	OFF	DISABLES SERIAL TOUCHSCREEN SUPPORT
	ON	ENABLES SERIAL TOUCHSCREEN SUPPORT
DIP SWITCH #5	OFF	RESERVED
	ON	RESERVED
DIP SWITCH #6	OFF	NOT USED
	ON	NOT USED
DIP SWITCH #7	OFF	NOT USED
	ON	NOT USED
DIP SWITCH #8	OFF	NORMAL RESET
	ON	HARD RESET*

* Only available on request for specific games.

On-board and external DKEY

An external identification key connector is available providing the cabinet's unique serial number.

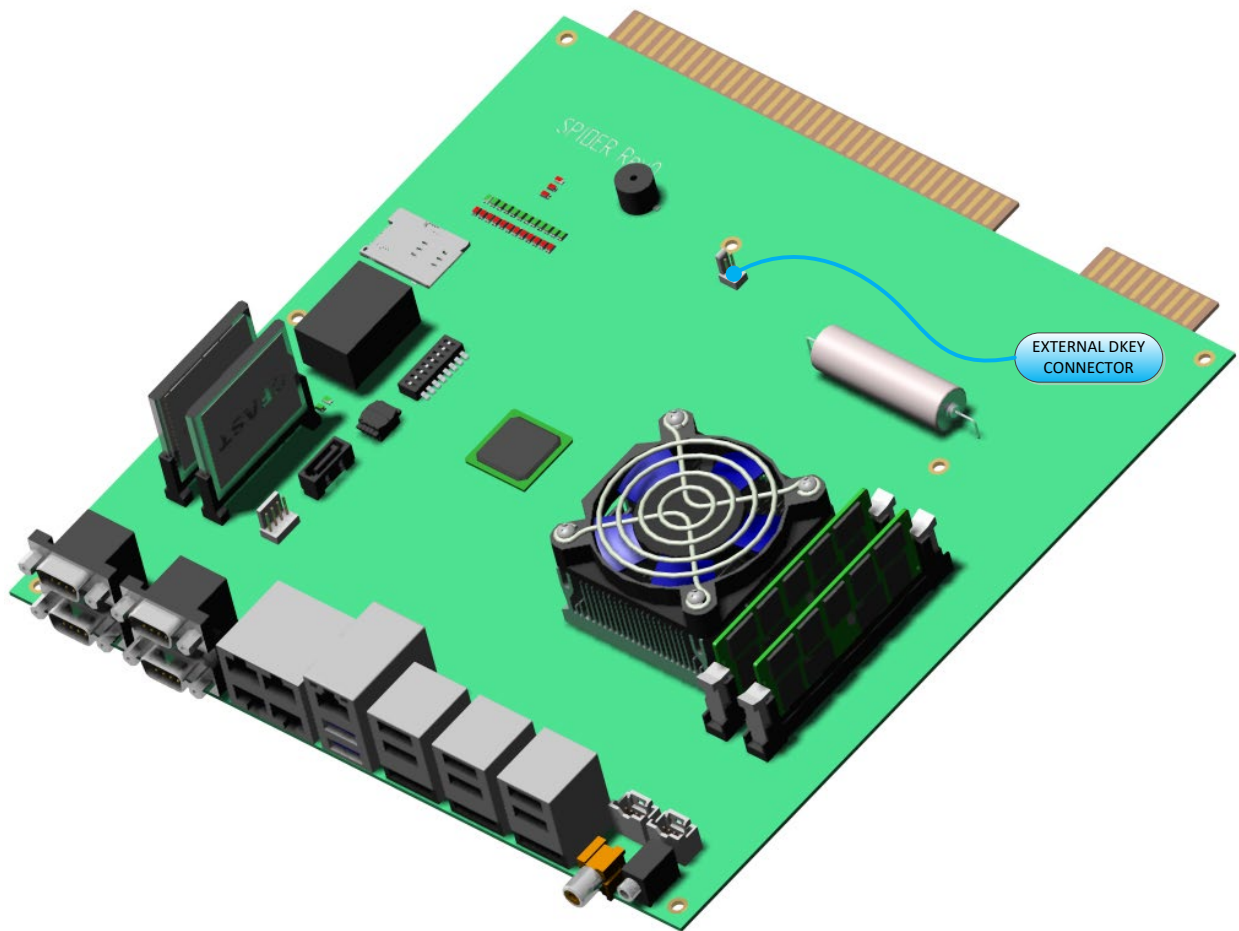

An on-board identification key is available providing the Spider's CPU board unique serial number.

Peripherals

Bill Acceptor (optional)

The bill acceptor communicates with the gaming board through an RS-232 link.

Manufacturer	Model	Nominal Voltage
JCM	UBA (UBA-10-SS)	12 VDC
JCM	iVIZION	12 VDC
MEI	SC Advance SCN6607E	12 VDC

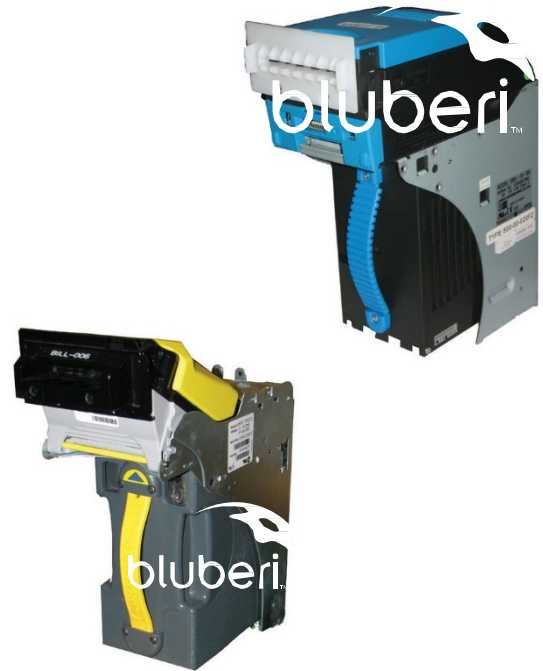

Printer (optional)

The ticket printer communicates with the gaming board through an RS-232 link.

Manufacturer	Model	Nominal Voltage
Nanoptix	Paycheck 4	24 VDC
JCM	GEN 5	24 VDC
Transact	Epic 950L	24 VDC



Deck LCD Panel

The deck door LCD monitor screen is cut (half-cut) from a 16:9 aspect ratio 27" LCD. It measures approximately 24.4" in diagonal and gives an aspect ratio of 16:4.5. It is controlled by a DVI interface, thus maximizing the visual quality.

Input Power	Video Signal	Aspect Ratio
+12VDC @ 1.5A	1920 × 540 pixels	16:4.5

The monitor is equipped with a touchscreen communicating with the gaming board through a USB link.

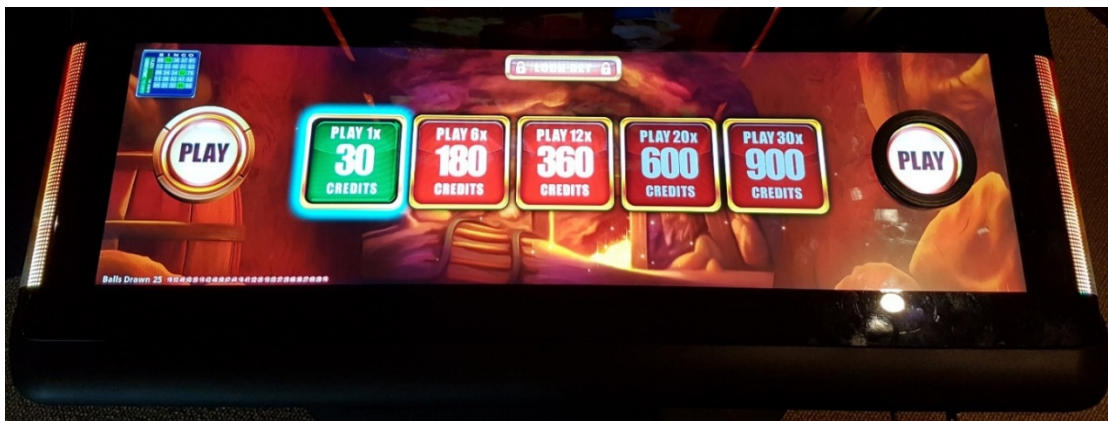

Upper Door LCD Monitors

The upper door LCD monitor screen measures 27" in diagonal with 16:9 aspect ratio. It is controlled by a DVI interface, thus maximizing the visual quality.

Input Power	Video Signal	Aspect Ratio
+12VDC @ 2.8A	1920 × 1080 pixels	16:9

The lower monitor is equipped with a touchscreen communicating with the gaming board through a USB link.

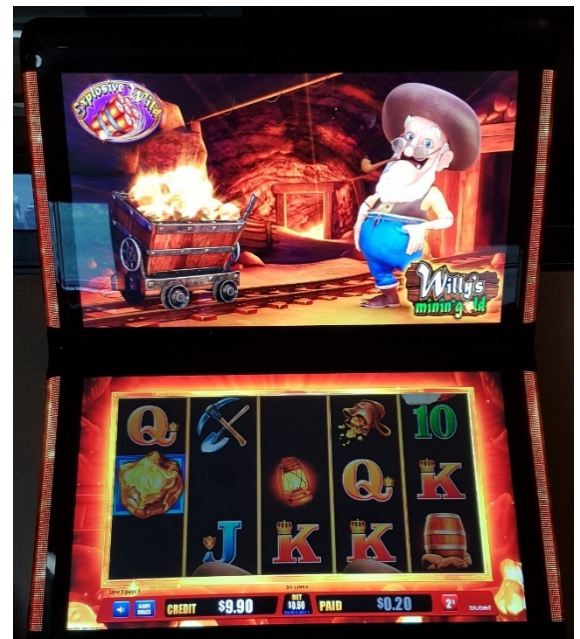

Curved Side LED bars

The cabinet feature side LED bars mounted underneath a curved glass. These LED bars are controlled and driven by a unique LED controller specifically designed for the Bluberi Novus series of cabinet.

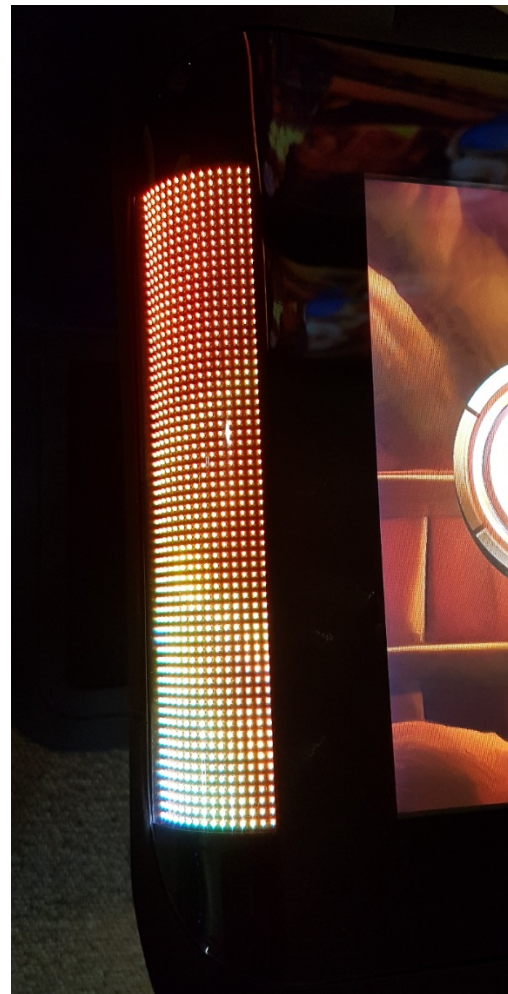
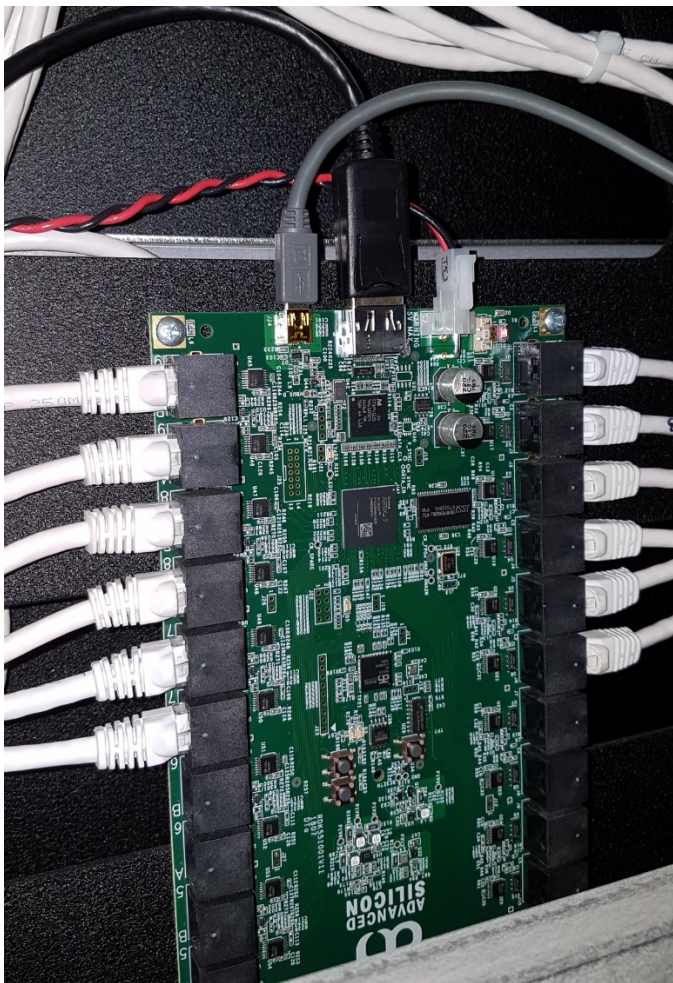

Mechanical Meters

Mechanical meters display game data using seven digits:

- cash in (1)
- cash paid (2)
- drop (3)
- cash won (4)
- cash played (5)



These meters, which cannot be reset, confirm data contained in the gaming board memory. They increment each time a 12 VDC pulse is registered. The hard meters are visible underneath the deck screen.

Network

The network connects gaming machines to a server through a Gigabit Ethernet link, making it possible to manage progressives as well as cashless and accounting systems.

Power Distribution Unit

The cabinet is powered using a power distribution unit (PDU) for both AC and DC voltages. PDU integrates the main AC power inlet with an EMI filter, a thermal breaker and the main switch. It also integrates an ATX-style power supply for DC rails power.

Parameter	Min.	Nom.	Max	Unit
Vin (115 VAC)	100	115	132	VACrms
Vin (230 VAC)	200	230	240	VACrms
Vin Frequency	47	-	63	HZ

Output Voltage	Min. Load	Max. Load	Load Reg.	Cross Reg.	Line Reg.	Ripple & Noise
+5V	0.3A	24A	±5%	±5%	±1%	50mVp.p
+12V	0.2A	50A	±5%	±5%	±1%	120mVp.p
+24V	0.2A	15A	±5%	±5%	±1%	160mVp.p
-12V	0A	1A	±10%	±10%	±2%	120mVp.p
+5VSB	0A	3A	±5%	±5%	±1%	50mVp.p

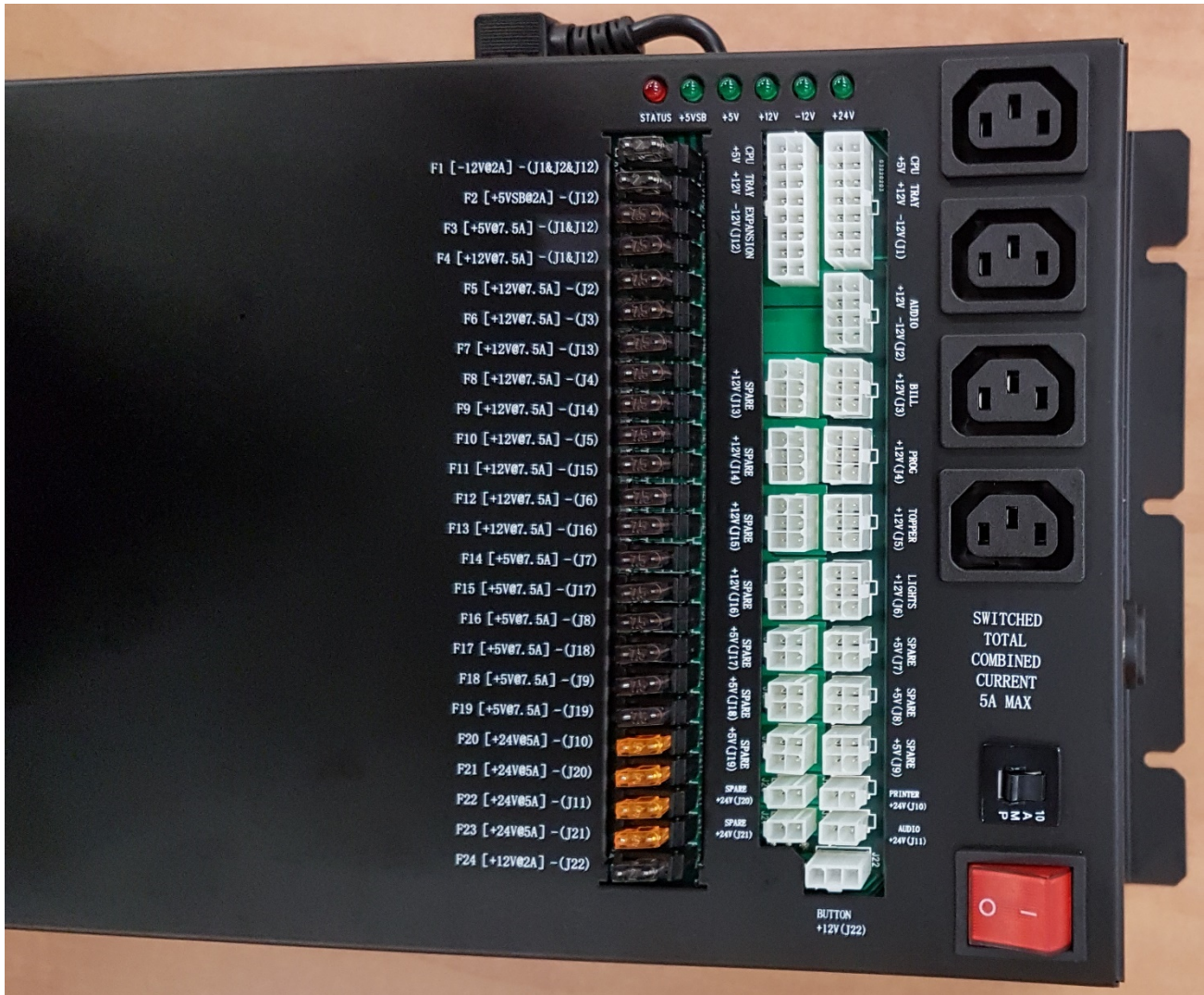

Each component inside the cabinet is powered independently from the power distribution unit. Each segment is fuse protected. To quickly determine whether a fuse is blown, check the LED under it.

- LED ON: Fuse is OK
- LED OFF: Fuse is blown



Input current is limited to 15A. **Use of an IEC C13 16AWG (SJT) detachable power cord is mandatory for the application.**



PDU DC Section	
CPU Tray (J1)	This output supplies power to the CPU enclosure (main board).
Audio (J2)	-- Unused --
Bill +12V (J3)	This output supplies power to the bill acceptor.
Prog. +12V (J4)	This output supplies power to the deck door section (LCD panel + LED bars) .
Topper +12V (J5)	-- Unused --
Lights +12V (J6)	This output supplies power to the chassis fans, the belly logo, service/collect buttons lamp & candlelight.
Spare +5V (J7)	This output supplies power to the deck door section (USB charger) .
Spare +5V (J8)	This output supplies power to the main LED controller and DP splitter.
Spare +5V (J9)	-- Unused --
Printer +24V (J10)	This output supplies power to the ticket printer.
Audio +24V (J11)	This output supplies +24V power to the audio amplifier board.
CPU Expansion (J12)	This output supplies power to the CPU enclosure (expansion power).
Spare +12V (J13)	This output supplies power to the upper door first LCD (touch) & LED bars.
Spare +12V (J14)	This output supplies power to the upper door second LCD & LED bars.
Spare+12V(J15)	This output supplies power to the optional topper LCD & LED bars.
Spare +12V (J16)	-- Unused --
Spare +5V (J17)	-- Unused --
Spare +5V (J18)	-- Unused --
Spare +5V (J19)	-- Unused --
Spare +24V (J20)	-- Unused --
Spare +24V (J21)	-- Unused --
Button +12V (J22)	This output supplies power to the service lamp.

Switched AC Outlets

The power distribution unit (PDU) features four (4) switched AC outputs on IEC 320 C14 outlets. Total combined current for those four outlets is 10A (10A thermal breaker). Those outlets are intended for use with cabinet standard components such as monitors. They will be cycled with the rocker switch.



Unswitched AC Outlets

The power distribution unit (PDU) features two (2) unswitched AC outputs on IEC 320 C14 outlets. Total combined current for those two outlets is 5A (5A thermal breaker). Those outlets are intended for use with external add-on components such as player interface SMIB. Power will be available on those outlets even if the main rocker switch is in off position.



AC Fault Condition

If a fault condition (excessive current) has been detected on one or many AC outlets, the corresponding AC outlets group (switched or unswitched) will be disabled (tripped thermal breaker). Fix faulty condition on AC outlets and push thermal breaker actuator back in.



Sound Amplifier, Subwoofer and Speakers

The subwoofer and speakers are driven by the AMP21XP, a dedicated board amplifying the left and right outputs of the gaming board and adding a special output for a loudspeaker.

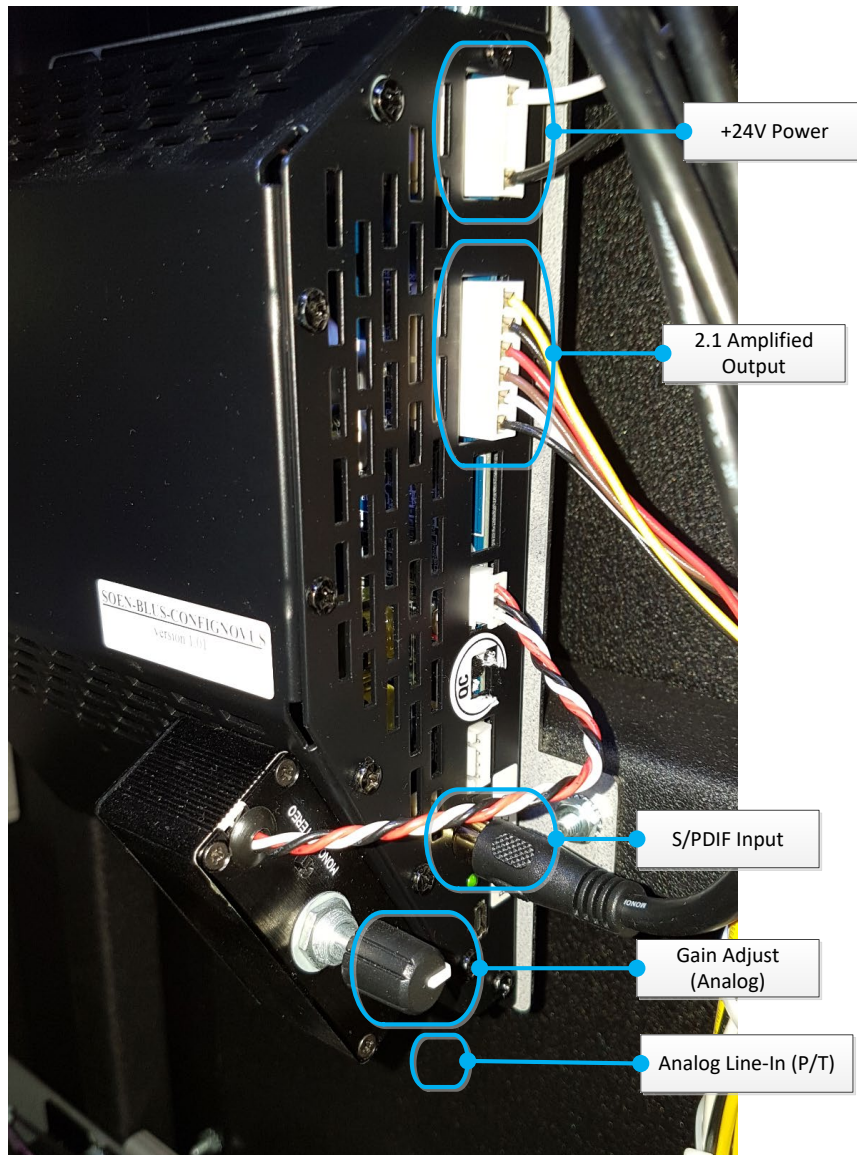







Contact Us



If you have any question, comment or feedback, please use the contact details provided below.

Bluberi Gaming Canada Inc.

2120, rue Letendre
Drummondville (Québec) J2C 7E9
CANADA

 819.475.5155
1.800.720.5155 (U.S. toll-free number)
 819.475.5156
 www.bluberi.com

Technical Support

 1.866.THE.GAME (1.866.843.4263)
 support.bluberi.com
 support@bluberi.com

© 2019 Bluberi Gaming Canada Inc.

All rights reserved. No part of this document may be reproduced, in any form or by any means, without prior written authorization from Bluberi Gaming Canada Inc.

The information contained in this document represents the current view of Bluberi on the issues discussed as of the date of publication. Because Bluberi must respond to changing market conditions, the comprised information should not be interpreted as a commitment on the part of Bluberi, and Bluberi does not guarantee the accuracy of any presented information.

This document is for informational purposes only. BLUBERI MAKES NO WARRANTIES, EXPRESSED OR IMPLIED, IN THIS DOCUMENT.

Other product and company names mentioned herein may be the trademarks of their respective owners.